

MANUFACTURED BY:

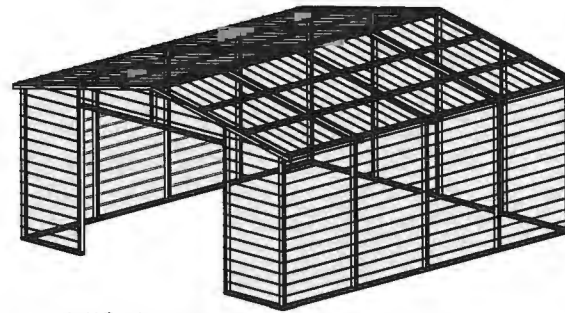

REGULAR / A-FRAME 22'-0" WIDE CARPORT STYLE BUILDINGS

DESIGN NOTES

1. ALL CONSTRUCTION SHALL BE PROVIDED IN ACCORDANCE WITH IBC 2018, OSHA, AISC 360, AISI 100, ASCE 7-16, AWS D1.3 CODES AND ALL APPLICABLE LOCAL REQUIREMENTS.
2. ALL MATERIALS IDENTIFIED BY MANUFACTURER NAME MAY BE SUBSTITUTED WITH MATERIAL EQUAL OR EXCEEDING ORIGINAL.
3. ALL SHOP CONNECTIONS SHALL BE WELDED CONNECTIONS.
4. ALL STRUCTURAL FIELD CONNECTIONS SHALL BE #12-14 X 3/4" SDS (ESR-2196 OR EQ) WITHOUT WASHERS.
5. STEEL SHEATHING SHALL BE 29GA CORRUGATED GALV. OR PAINTED STEEL - MAIN RIB HT. 3/4" (FY=80KSI) OR EQ. CONNECTIONS SHALL BE #12-14 X 3/4" SDS (ESR-2196 OR EQ) WITH NEOPRENE WASHERS.
6. ALL STRUCTURAL LIGHT GAUGE TUBING AND CHANNELS SHALL BE GRADE 50 STEEL (FY = 50 KSI, FU = 65 KSI).
7. STRUCTURAL TUBE 2 1/2" X 2 1/2" - 14GA. IS EQUIVALENT TO TS 2 1/4" X 2 1/4" - 12GA AND EITHER ONE MAY BE USED IN LIEU OF THE OTHER.
8. GYPSUM BOARD OR DRYWALL FINISH OR ANY BRITTLE BASE MATERIAL IS NOT CONSIDERED OR ACCOUNTED FOR ON THE DESIGN CRITERIA.
9. ALL DESIGN CRITERIA MUST BE INCREASED TO THE NEXT HIGHER INCREMENT BASED ON THE TABLES ON PAGE 4. NO INTERPOLATION IS ALLOWED.

DESIGN CRITERIA

PREVAILING CODE:	MBC 2015 (IBC 2015)
USE GROUP:	U (CARPORTS, BARNs)
RISK CATEGORY:	1
1. ROOF DEAD LOAD (D)	D = 4 PSF
2. ROOF LIVE/SNOW LOAD (Lr)	Lr = 20 - 61 PSF (AS PER SNOW LOAD SEE TABLE 4)
3. SNOW LOAD (S)	
GROUND SNOW LOAD	P _g = 20 - 90 PSF
IMPORTANCE FACTOR	I _s = 0.8
THERMAL FACTOR	C _t = 1.2
EXPOSURE FACTOR	C _e = 1.0
ROOF SLOPE FACTOR	C _s = 1.0
4. WIND LOAD (W)	
BASIC WIND SPEED	V _{ULT} = 105 - 180 MPH
EXPOSURE	C
5. SEISMIC LOAD (E)	
DESIGN CATEGORY	D
IMPORTANCE FACTOR	I _e = 1.00

LOAD COMBINATIONS:

1. D + (Lr OR S)
2. D + (0.6W OR ±0.7E)
3. D + 0.75 (0.6W OR ±0.7E) + 0.75 (Lr OR S)
4. 0.6D + (0.6W OR ±0.7E)

DRAWING INDEX

COVER SHEET	----	1
SCHEDULES & MEMBER -		
SECTIONS	----	2
FRAME SECTIONS & DETAILS	----	3-A, 3-B
SPACING SCHEDULES -		
& ENCLOSURE NOTES	----	4
PURLIN & GIRT SCHEDULES	----	5
SHEATHING OPTIONS	----	6
SIDE WALL FRAMING		
& OPENINGS	----	7-A, 7-B
END WALL FRAMING		
& OPENINGS	----	8-A, 8-B
CORNER BRACING DETAILS	----	9
OPTIONAL LEAN-TO ADDITION	----	10
FOUNDATION OPTIONS	----	11-A TO 11-D

DRAWING INFORMATION

PROJECT: 22'-0" WIDE BUILDINGS

LOCATION: STATE OF MICHIGAN

PROJECT NO.: 451-22-1572

SHEET TITLE:

COVER SHEET

SHEET NO.: 1 / 11

DRAWN BY: AW DATE: 5/17/22

CHECKED BY: OAA DATE: 5/17/22

LEGAL INFORMATION

- ANY DUPLICATION OF THIS DRAWING IN WHOLE OR PART IS STRICTLY FORBIDDEN. ANYONE DOING SO WILL BE PROSECUTED UNDER THE FULL EXTENT OF THE LAW.
- DRAWINGS VALID UP TO 1 YEAR FROM DATE OF ISSUE.

SEAL:

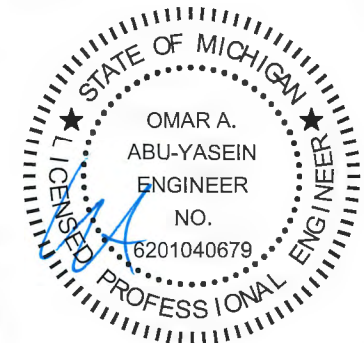

CUSTOMER INFORMATION

OWNER:
ADDRESS:

DESIGN LOADS

GROUND SNOW:

ROOF LIVE LOAD:

BASIC WIND SPEED:

BUILDING INFORMATION

WIDTH:

LENGTH:

HEIGHT:

FRAME TYPE:

ENCLOSURE TYPE:

- A-FRAME
 REGULAR
 FULL
 PARTIAL
 OPEN

CERTIFICATION VALIDITY NOTICE

DATE OF PLANS EXPIRATION: **05-20-2023**

CERTIFICATION ON THESE DRAWINGS IS VALID FOR ONE YEAR FROM DATE OF ISSUE

DATE EXPIRES: **03-24-2024**

DATE SIGNED: **05-20-2022**

TABLE 2.1: MEMBER PROPERTIES

NO.	LABEL	PROPERTY	DETAIL NO.
1	COLUMN POST	2.5" X 2.5" X 14GA TUBE	1
2	ROOF BEAM	2.5" X 2.5" X 14GA TUBE	1
3	BASE RAIL	2.5" X 2.5" X 14GA TUBE	1
4	PEAK BRACE	2.5" X 2.5" 14GA CHANNEL	4
5	KNEE BRACES	2.5" X 1.5" 14GA CHANNEL	4
6	CONNECTOR SLEEVE	2.25" X 2.25" X 12GA TUBE	2
7	BASE ANGLE	2" X 2" X 3" LG. 3/16" ANGLE	10
8	PURLIN	4.25" X 1.5" X 14GA / 18GA HAT CHANNEL	5
9	GIRT	4.25" X 1.5" X 14GA / 18GA HAT CHANNEL	5
9A	OPT. END WALL GIRT	2.5" X 1.5" 14GA CHANNEL	1
10	SHEATHING	29 GA CORRUGATED SHEET	8
11	END WALL POST	2.5" X 2.5" X 14GA TUBE	1
12	DOOR POST	2.5" X 2.5" X 14GA TUBE	1
13	SINGLE HEADER	2.5" X 2.5" X 14GA TUBE	1
14	DOUBLE HEADER	DBL. 2.5" X 2.5" X 14GA TUBE	1
15	SERVICE DOOR / WINDOW FRAMING	2.5" X 2.5" X 14GA TUBE	1
16	ANGLE BRACKET	2" X 2" X 2" LG. 14GA ANGLE	7
17	STRAIGHT BRACKET	2" X 2" X 4" LG. 14GA PLATE	6
18	PB SUPPORT	2.5" X 2.5" X 14GA TUBE	1
19	DIAGONAL BRACE	2" X 2" X 14 GA TUBE	3
20	GABLE BRACE	2" X 2" X 14 GA TUBE	3
21	DB BRACKET	2.25" X 2.25" X 6" LG. 14GA ANGLE	9
22	TRUSS SPACER	2.5" X 2.5" X 14GA TUBE	1
23	ALL FASTENERS	#12 X 1" SELF-DRILL SCREWS (ESR-2196 OR EQ) W/ NEOPRENE/STEEL WASHER	

TABLE 2.2: SHEATHING FASTENER SCHEDULE

LOCATION	CORNER PANELS	SIDE LAPS	EDGE LAPS	ELSEWHERE
SPACING	9" C/C	MIN. 1	4 1/2" C/C	9" C/C

FASTENER TYPE: #12X1" SELF-DRILL SCREWS (ESR-2196 OR EQ) W/ NEOPRENE/STEEL WASHER

*SEE TYP. SHEATHING FASTENER SCHEDULE DIAGRAM ON PAGE 6.

TABLE 2.3: GAUGE THICKNESS

GAUGE	29	18	14	12
THICKNESS (IN)	0.0135	0.049	0.083	0.109

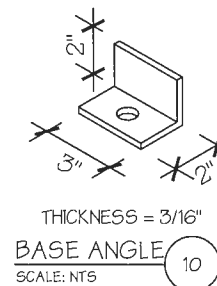
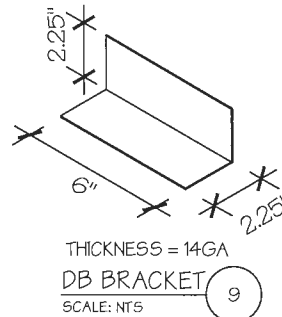
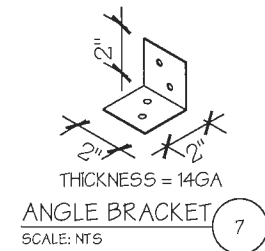
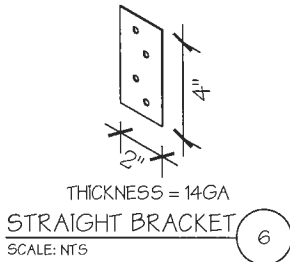
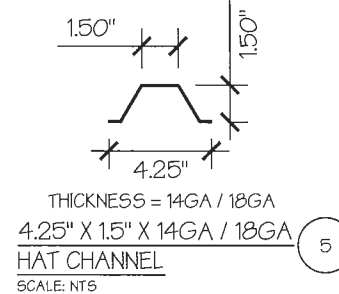
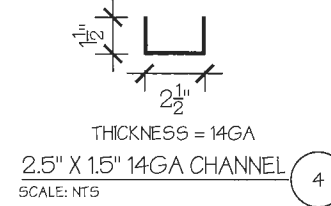
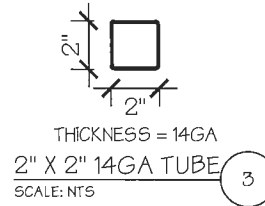
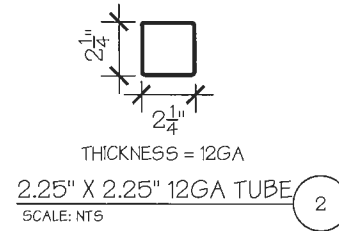
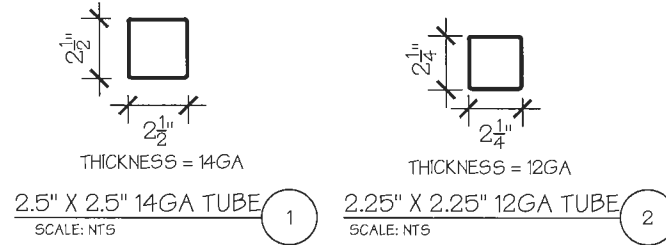
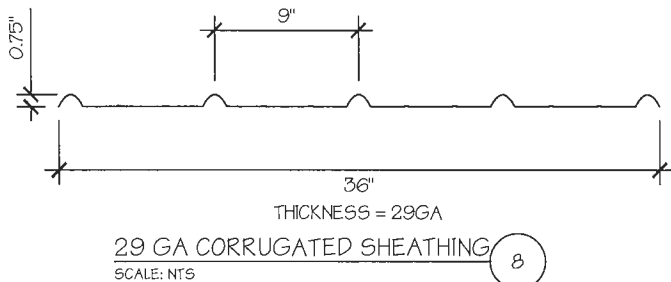

MANUFACTURED BY:



DRAWING INFORMATION

PROJECT: 22'-0" WIDE BUILDINGS

LOCATION: STATE OF MICHIGAN

PROJECT NO.: 451-22-1572

SHEET TITLE:

SCHEDULES & MEMBER SECTIONS

SHEET NO.: 2 / 11

DRAWN BY: AW DATE: 5/17/22

CHECKED BY: OAA DATE: 5/17/22

LEGAL INFORMATION

- ANY DUPLICATION OF THIS DRAWING IN WHOLE OR PART IS STRICTLY FORBIDDEN. ANYONE DOING SO WILL BE PROSECUTED UNDER THE FULL EXTENT OF THE LAW. - DRAWINGS VALID UP TO 1 YEAR FROM DATE OF ISSUE.

SEAL:

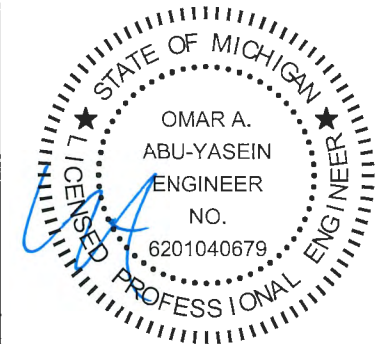

DATE EXPIRES: 03-24-2024

DATE SIGNED: 05-20-2022

MANUFACTURED BY:

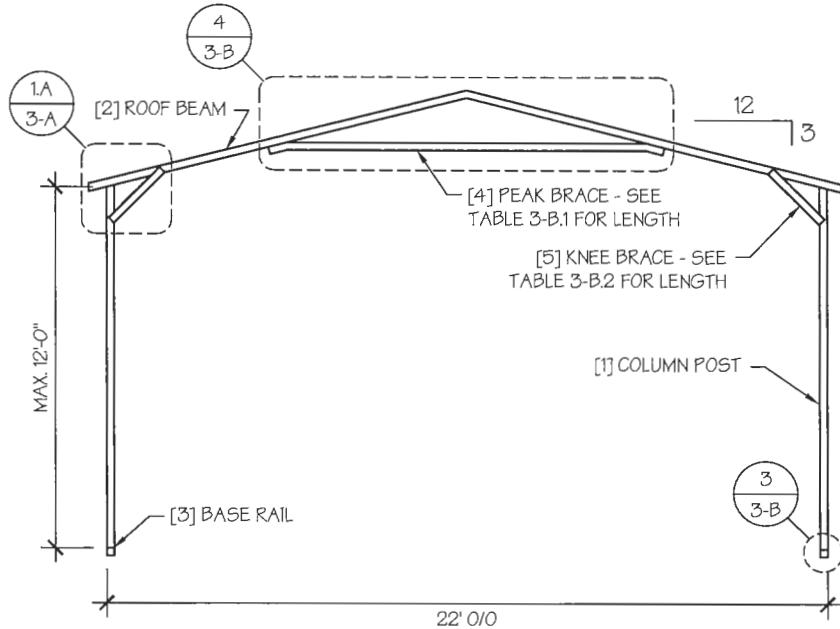

TYP. A-FRAME SECTION
SCALE: NTS

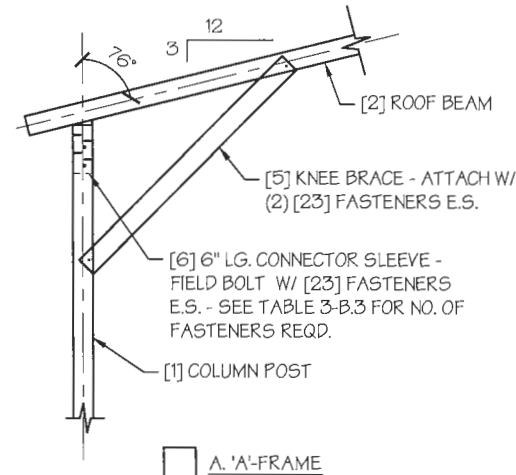

A. A-FRAME

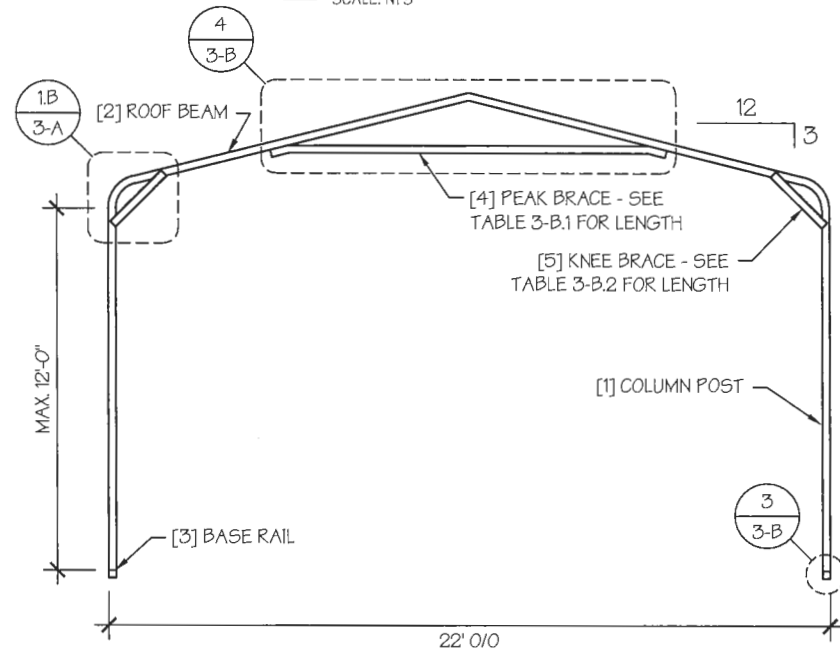

TYP. REGULAR FRAME SECTION
SCALE: NTS

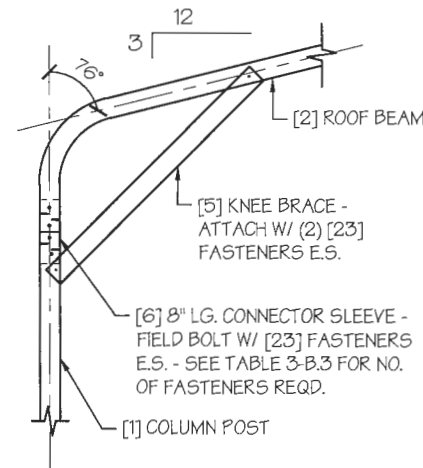

B. REGULAR-FRAME

EAVE DETAIL
SCALE: NTS

DRAWING INFORMATION

PROJECT: 22'-0" WIDE BUILDINGS

LOCATION: STATE OF MICHIGAN

PROJECT NO.: 451-22-1572

SHEET TITLE:

FRAME SECTIONS & DETAILS

SHEET NO.: 3-A / 11

DRAWN BY: AW DATE: 5/17/22

CHECKED BY: OAA DATE: 5/17/22

LEGAL INFORMATION

- ANY DUPLICATION OF THIS DRAWING IN WHOLE OR PART IS STRICTLY FORBIDDEN. ANYONE DOING SO WILL BE PROSECUTED UNDER THE FULL EXTENT OF THE LAW.
- DRAWINGS VALID UP TO 1 YEAR FROM DATE OF ISSUE.

SEAL:

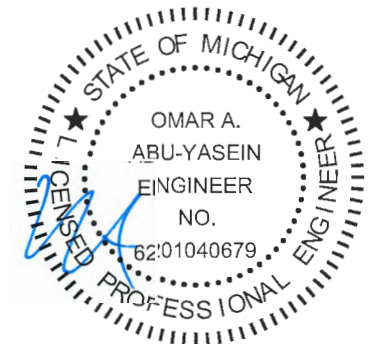

DATE EXPIRES: 03-24-2024

DATE SIGNED: 05-20-2022

MANUFACTURED BY:

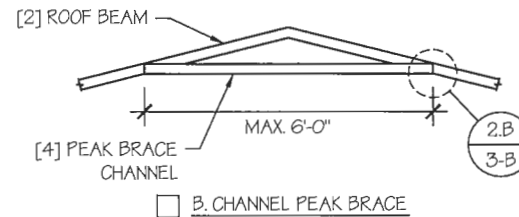
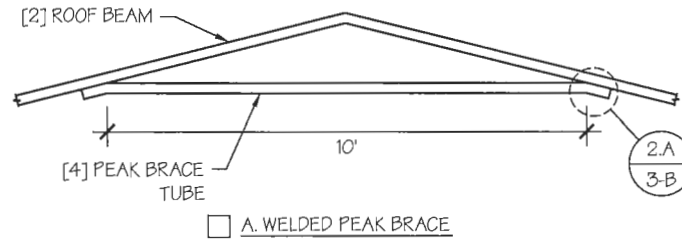
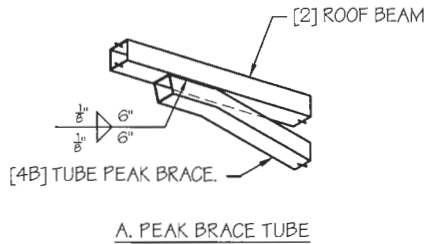

PEAK BRACE DETAILS 4
SCALE: NTS

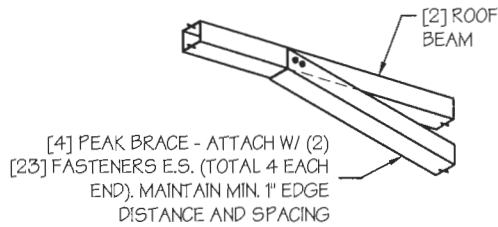

PEAK BRACE CONNECTION DETAILS 2
SCALE: NTS

[6] 6" LG. CONNECTOR SLEEVE.
FIELD BOLT W/ [23] FASTENERS
- SEE TABLE 3-B.3 FOR NO. OF FASTENERS REQD.

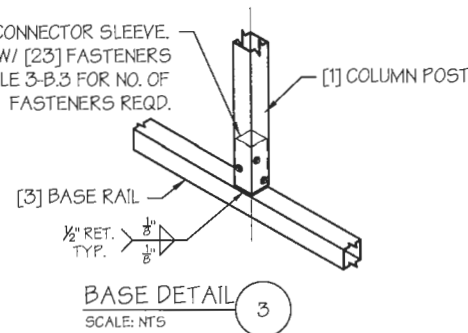

TABLE 3-B.1: PEAK BRACE SCHEDULE

GROUND SNOW / ROOF LIVE LOAD (PSF)	WIND SPEED	
	□ 105 TO 130	□ 140 TO 180
□ 30 / 20	6'	10'
□ 35 / 25 TO 90 / 61	10'	10'

TABLE 3-B.2: KNEE BRACE SCHEDULE

EAVE HEIGHT	KNEE BRACE LENGTH
□ UP TO 8'	24"
□ 9' TO 12'	36"

TABLE 3-B.3 FASTENER SCHEDULE

WIND SPEED (MPH)	NO. OF FASTENERS
□ 105 TO 125	4
□ 130 TO 155	6
□ 160 TO 180	8

NOTE: COLUMN POST MAY BE ADJUSTED ±1" FOR LEVELING.
MANUFACTURER IS NOT RESPONSIBLE FOR LEVELING OF GROUND AND/OR CONCRETE SURFACE PROVIDED BY OTHERS.

DRAWING INFORMATION

PROJECT: 22'-0" WIDE BUILDINGS
LOCATION: STATE OF MICHIGAN
PROJECT NO.: 451-22-1572
SHEET TITLE:

FRAME DETAILS

SHEET NO.: 3-B / 11
DRAWN BY: AW DATE: 5/17/22
CHECKED BY: OAA DATE: 5/17/22

LEGAL INFORMATION

- ANY DUPLICATION OF THIS DRAWING IN WHOLE OR PART IS STRICTLY FORBIDDEN. ANYONE DOING SO WILL BE PROSECUTED UNDER THE FULL EXTENT OF THE LAW.
- DRAWINGS VALID UP TO 1 YEAR FROM DATE OF ISSUE.

SEAL:

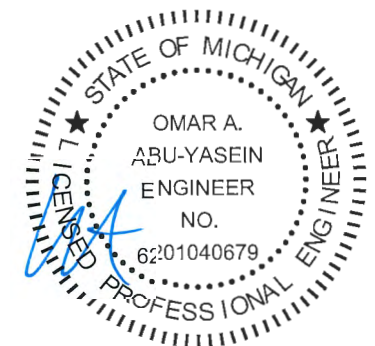

DATE EXPIRES: 03-24-2024
DATE SIGNED: 05-20-2022

MANUFACTURED BY:



TABLE 4: FRAME SPACING CHART / SCHEDULE

GROUND SNOW / ROOF LIVE LOAD (PSF)	■ ENCLOSED BUILDINGS							■ OPEN BUILDINGS						
	WIND SPEED (MPH)							WIND SPEED (MPH)						
	□105	□115	□130	□140	□155	□165	□180	□105	□115	□130	□140	□155	□165	□180
□ 30 / 20	60	60	54/60	54	42	36	30	48	48	48	42/48	36/42	36	30
□ 40 / 27	48/60	48/60	42/60	42/54	42	36	30	42	42	42	42	36/42	36	30
□ 50 / 34	40/48	40/48	40/48	40/48	40/48	36	30	36	30	30	30	30	30	30
□ 60 / 41	36	36	36	36	36	36	30	30	30	30	30	30	30	30
□ 70 / 47	30	30	30	30	30	30	30	24	24	24	24	24	24	24
□ 80 / 54	24	24	24	24	24	24	24	24	18	18	18	18	18	18
□ 90 / 61	24	24	24	24	24	24	24	---	---	---	---	---	---	---
□ 30 / 20	60	60	54/60	54	48	42/48	36	54	54	48/54	42/54	36/48	36/42	36
□ 40 / 27	48/60	48/60	42/60	42/54	42/48	42/48	36	42	42	42	42	36/42	36/42	36
□ 50 / 34	40/48	40/48	40/48	40/48	40/48	40/48	36	36	36	36	36	36	36	36
□ 60 / 41	36	36	36	36	36	36	36	30	30	30	30	30	30	30
□ 70 / 47	30	30	30	30	30	30	30	24	24	24	24	24	24	24
□ 80 / 54	24	24	24	24	24	24	24	24	24	24	24	24	24	24
□ 90 / 61	24	24	24	24	24	24	24	---	---	---	---	---	---	---
□ 30 / 20	60	60	54/60	54	48	42/48	42	60	54/60	48/60	42/54	36/48	36/42	36
□ 40 / 27	48/60	48/60	42/60	42/54	42/48	42/48	42	48/54	48/54	42/54	42/54	36/48	36/42	36
□ 50 / 34	40/48	40/48	40/48	40/48	40/48	40/48	40/42	40/42	40/42	40/42	40/42	36/42	36/42	36
□ 60 / 41	36	36	36	36	36	36	36	36	36	36	36	36	36	36
□ 70 / 47	30	30	30	30	30	30	30	30	30	30	30	30	30	30
□ 80 / 54	24	24	24	24	24	24	24	24	24	24	24	24	24	24
□ 90 / 61	24	24	24	24	24	24	24	24	24	24	24	24	24	24

EAVE HEIGHT = 10'-0" TO 12'-0"

EAVE HEIGHT = 7'-0" TO 9'-0"

EAVE HEIGHT = UP TO 6'-0"

NOTES:

1. FRAME SPACINGS ARE IN UNITS OF INCHES (IN).
2. WHERE TWO VALUES ARE SHOWN, THE HIGHER VALUE CAN ONLY BE USED FOR VERTICAL SHEATHING.
3. SNOW LOADS AND ROOF LIVE LOADS ARE IN POUNDS PER SQUARE FOOT (PSF). WIND SPEED IS 3 SEC. GUST IN MILES PER HOUR (MPH).
4. FOR VALUES THAT LIE BETWEEN TWO CELLS, THE HIGHER (MORE STRINGENT) VALUE HAS TO BE USED. INTERPOLATION BETWEEN CELLS IS NOT ALLOWED.

ENCLOSURE CLASSIFICATION:

1. ENCLOSED BUILDING = ALL 4 WALLS FULLY ENCLOSED WITH DOORS/WINDOWS = USE ENCLOSED BUILDING SPACING CHART.
2. OPEN BUILDING = ALL 4 WALLS FULLY OPEN = USE OPEN BUILDING SPACING CHART.
3. 3FT PARTIALLY ENCLOSED = BOTH END-WALLS FULLY OPEN, WITH BOTH SIDE-WALLS ONLY 3FT ENCLOSED = USE OPEN BUILDING SPACING CHART.
4. PARTIALLY ENCLOSED = BOTH END-WALLS FULLY OPEN, WITH BOTH SIDE-WALLS ENCLOSED MORE THAN 3FT = START WITH OPEN BUILDING SPACING CHART AND THEN REDUCE SPACING BY 6".
5. 3 SIDED ENCLOSED = ALL WALLS ARE ENCLOSED EXCEPT FOR 1 END-WALL = START WITH ENCLOSED BUILDING SPACING + THE OPEN END FRAME MUST HAVE EITHER A GABLED END OR HAVE DOUBLED WELDED LEGS & ROOF.
6. FOR ALL SHEATHING ENCLOSURES NOT LISTED ABOVE, REFER TO SHEET 5 FOR SPACING AND DESIGN REQUIREMENTS.

GENERAL NOTES:

1. THE MAX. BUILDING LENGTH FOR ENCLOSED BUILDINGS IS 50'-0". THIS CAN BE INCREASED BY ADDING A DOUBLE FRAME AT THE CENTER TO BREAK THE LENGTH OF THE BUILDING.
2. BUILDINGS WITH PARTIALLY ENCLOSED END WALLS NEED TO HAVE SIDE WALL BRACING TO SUPPORT THE PARTIALLY ENCLOSED END WALL. (SEE FIGURE A ON SHEET 5).
3. ALL BUILDINGS WITH AN OPEN END WALL MUST HAVE A 10'-0" TUBE PEAK BRACE.

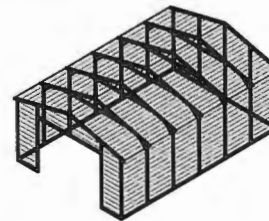

TYP. ENCLOSED BUILDING

SCALE: NTS

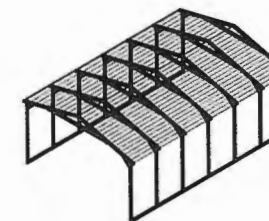

TYP. OPEN BUILDING

SCALE: NTS

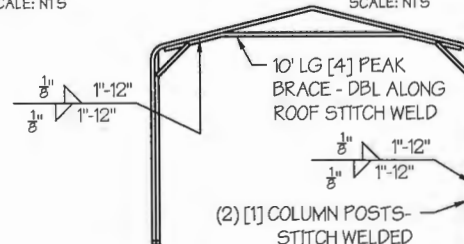

TYP. OPEN END WALL ON 3 SIDE ENCLOSED BUILDING

SCALE: NTS

DRAWING INFORMATION

PROJECT: 22'-0" WIDE BUILDINGS

LOCATION: STATE OF MICHIGAN

PROJECT NO.: 451-22-1572

SHEET TITLE:

SPACING SCHEDULES & ENCLOSURE NOTES

SHEET NO.: 4 / 11

DRAWN BY: AW DATE: 5/17/22

CHECKED BY: OAA DATE: 5/17/22

LEGAL INFORMATION

- ANY DUPLICATION OF THIS DRAWING IN WHOLE OR PART IS STRICTLY FORBIDDEN. ANYONE DOING SO WILL BE PROSECUTED UNDER THE FULL EXTENT OF THE LAW. - DRAWINGS VALID UP TO 1 YEAR FROM DATE OF ISSUE.

SEAL:

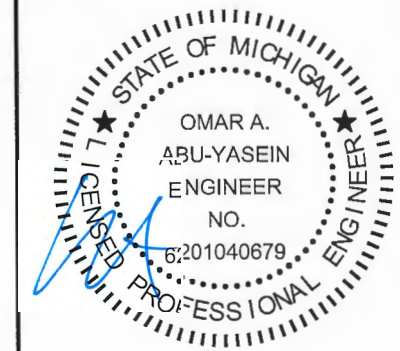

DATE EXPIRES: 03-24-2024

DATE SIGNED: 05-20-2022



DRAWING INFORMATION

PROJECT: 22'-0" WIDE BUILDINGS

LOCATION: STATE OF MICHIGAN

PROJECT NO.: 451-22-1572

SHEET TITLE:

PURLIN & GIRT SPACING SCHEDULES

SHEET NO.: 5 / 11

DRAWN BY: AW DATE: 5/17/22

CHECKED BY: OAA DATE: 5/17/22

LEGAL INFORMATION

- ANY DUPLICATION OF THIS DRAWING IN WHOLE OR PART IS STRICTLY FORBIDDEN. ANYONE DOING SO WILL BE PROSECUTED UNDER THE FULL EXTENT OF THE LAW.
- DRAWINGS VALID UP TO 1 YEAR FROM DATE OF ISSUE.

SEAL:

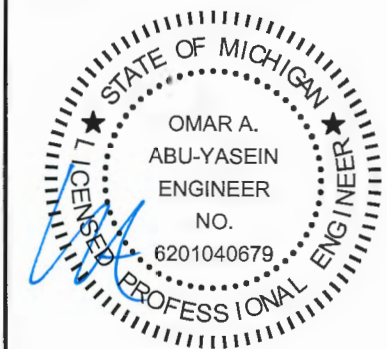

DATE EXPIRES: 03-24-2024

DATE SIGNED: 05-20-2022

TABLE 5.1: PURLIN SPACING SCHEDULE

GROUND SNOW / ROOF LIVE LOAD (PSF)	14GA. HAT CHANNEL PURLIN							18GA. HAT CHANNEL PURLIN						
	WIND SPEED (MPH)							WIND SPEED (MPH)						
	105	115	130	140	155	165	180	105	115	130	140	155	165	180
30 / 20	54	48	42	36	30	24	24	36	30	24	18	18	12	12
40 / 27	42	42	42	36	30	24	24	30	30	24	18	18	12	12
50 / 34	40	40	40	36	30	24	24	24	24	24	18	18	12	12
60 / 41	36	36	36	36	30	24	24	18	18	18	18	18	12	12
70 / 47	32	32	32	32	30	24	24	18	18	18	18	18	12	12
80 / 54	30	30	30	30	30	24	24	18	18	18	18	18	12	12
90 / 61	24	24	24	24	24	24	24	12	12	12	12	12	12	12
30 / 20	54	48	42	42	36	30	30	48	36	30	24	18	18	12
40 / 27	42	42	42	42	36	30	30	42	36	30	24	18	18	12
50 / 34	40	40	40	40	36	30	30	30	30	30	24	18	18	12
60 / 41	36	36	36	36	36	30	30	30	30	30	24	18	18	12
70 / 47	32	32	32	32	32	30	30	24	24	24	24	18	18	12
80 / 54	32	32	32	32	32	30	30	18	18	18	18	18	18	12
90 / 61	30	30	30	30	30	30	30	18	18	18	18	18	18	12
30 / 20	54	48	42	42	36	36	30	54	48	36	30	24	24	18
40 / 27	42	42	42	42	36	36	30	42	42	36	30	24	24	18
50 / 34	40	40	40	40	36	36	30	40	40	36	30	24	24	18
60 / 41	36	36	36	36	36	36	30	36	36	36	30	24	24	18
70 / 47	32	32	32	32	32	32	30	30	30	30	30	24	24	18
80 / 54	32	32	32	32	32	32	30	24	24	24	24	24	24	18
90 / 61	30	30	30	30	30	30	30	24	24	24	24	24	24	18
30 / 20	54	48	42	42	36	36	30	54	48	42	42	36	30	30
40 / 27	42	42	42	42	36	36	30	42	42	42	42	36	30	30
50 / 34	40	40	40	40	36	36	30	40	40	40	40	36	30	30
60 / 41	36	36	36	36	36	36	30	36	36	36	36	36	30	30
70 / 47	32	32	32	32	32	32	30	32	32	32	32	32	30	30
80 / 54	32	32	32	32	32	32	30	32	32	32	32	32	30	30
90 / 61	30	30	30	30	30	30	30	30	30	30	30	30	30	30

- NOTES:
- PURLIN SPACING UNITS ARE IN INCHES.
 - FRAME SPACING NEEDS TO BE DETERMINED FROM TABLE 4.

IRREGULAR BUILDING NOTES:

- FIGURES A, B, C & D ON THE RIGHT INDICATE EXAMPLES OF IRREGULAR BUILDINGS.
- FOR IRREGULAR BUILDINGS, FRAME SPACING MUST BE REDUCED BY 12" FROM OPEN BUILDING SPACING TABLE. SEE SHEET 4 FOR OPEN BUILDING TABLE.
- SITE SPECIFICS MAY ALLOW FOR ALTERNATIVE SPACING.
- IRREGULAR BUILDING & BUILDINGS W/ MORE THAN 2 SIDE OPENINGS MUST HAVE A 10' TUBE PEAK BRACE ON ALL FRAMES.

TABLE 5.2: GIRT SPACING SCHEDULE

FRAME SPACING	WIND SPEED (MPH)						
	105	115	130	140	155	165	180
5'-0"	60	48	36	30	24	24	18
4'-6"	60	60	48	42	36	30	24
4'-0"	60	60	54	54	42	36	30
3'-6"	60	60	54	54	48	42	42
2'-0" TO 3'-0"	60	60	54	54	48	42	42

NOTES:

- GIRT SPACING UNITS ARE IN INCHES.
- THIS SCHEDULE IS TO BE USED FOR BOTH 14GA AND 18 GA GIRTS.
- FRAME SPACING NEEDS TO BE DETERMINED FROM TABLE 4.

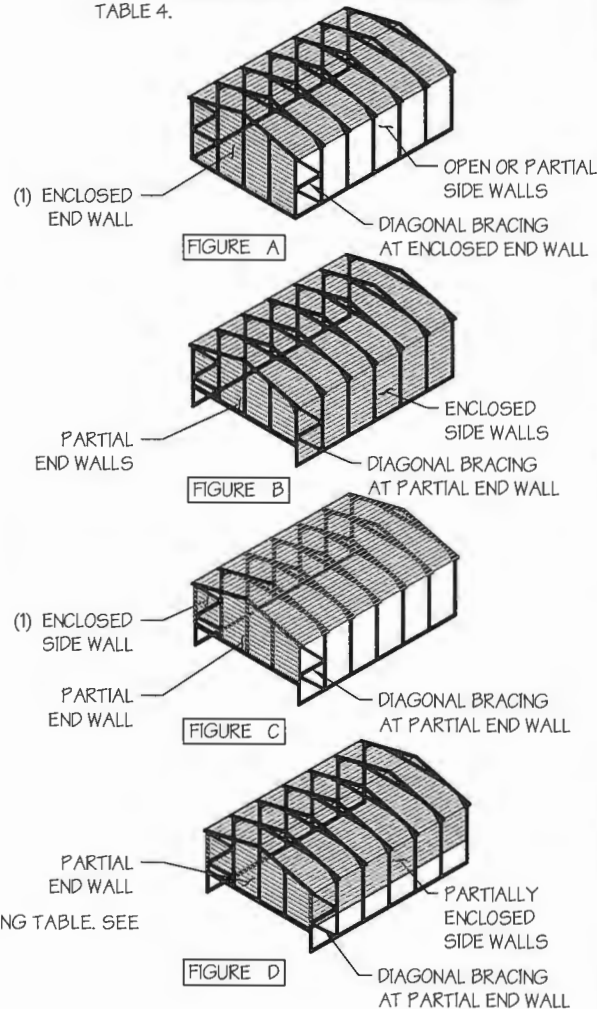

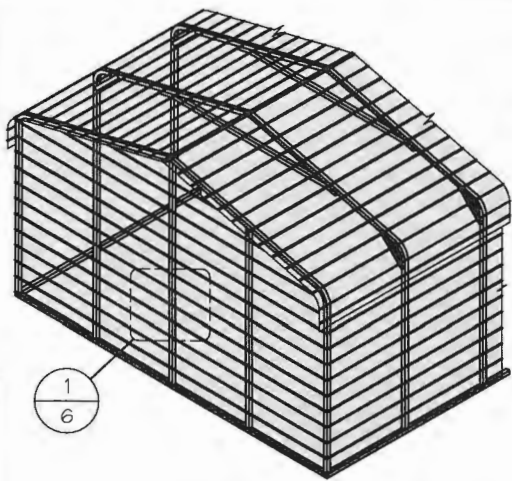

□ TYP. HORIZONTAL SHEATHING
SCALE: NTS

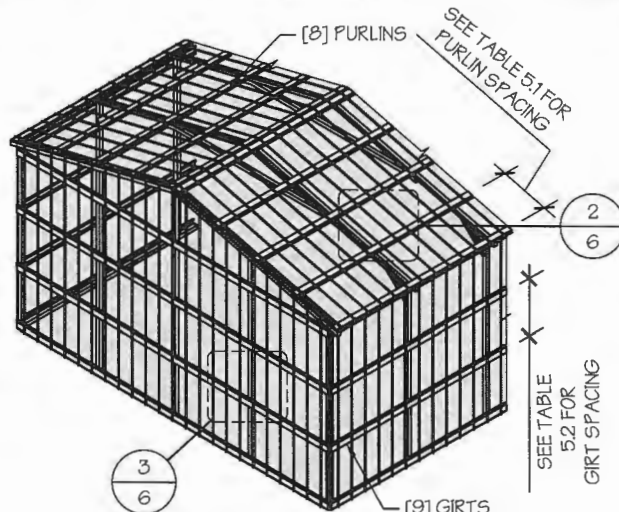

□ TYP. VERTICAL SHEATHING
SCALE: NTS

GENERAL SHEATHING NOTES:

1. REGULAR STYLE BUILDINGS CAN ONLY HAVE HORIZONTAL SHEATHING ON ROOF AND WALLS.
2. A-FRAME STYLE BUILDINGS CAN HAVE ANY COMBINATION OF HORIZONTAL OR VERTICAL SHEATHING ON ROOFS AND WALLS.
3. BOTH HORIZONTAL AND VERTICALS ROOF SHEATHING CAN HAVE MAX. 6" OVERHANG.
4. USING VERTICAL SHEATHING MAY ALLOW FOR GREATER FRAME SPACING. SEE NOTE 2 UNDER TABLE 4.
5. VERTICAL SHEATHING RECOMMENDED FOR BUILDINGS 30' OR LONGER

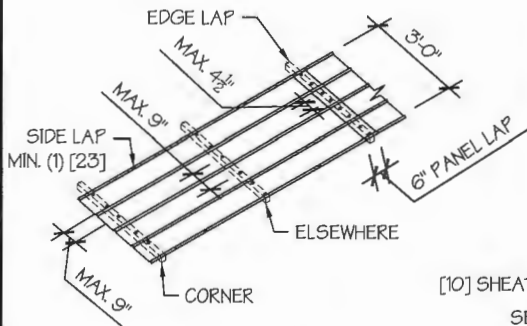

TYP. SHEATHING FASTENER SCHEDULE
SCALE: NTS

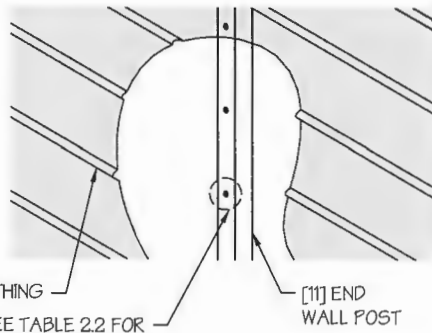

TYP. HORIZONTAL SHEATHING DETAIL 1
SCALE: NTS

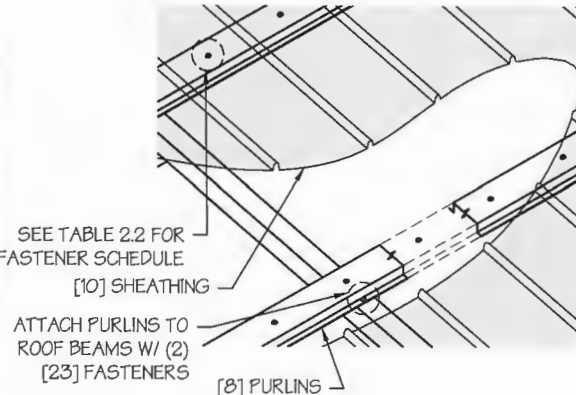

ROOF VERTICAL SHEATHING DETAIL 2
SCALE: NTS

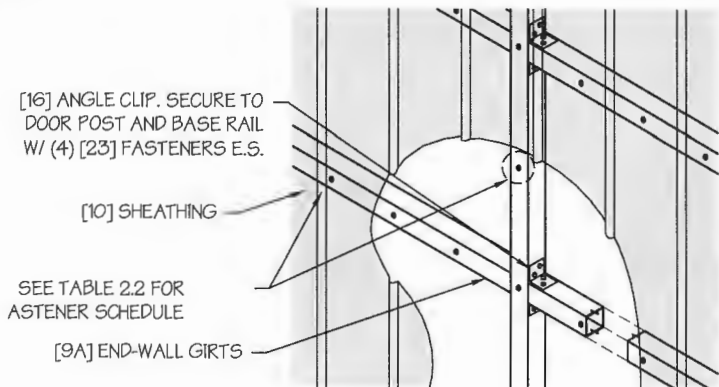

□ WALL VERTICAL SHEATHING - TUBE DETAIL 3
SCALE: NTS

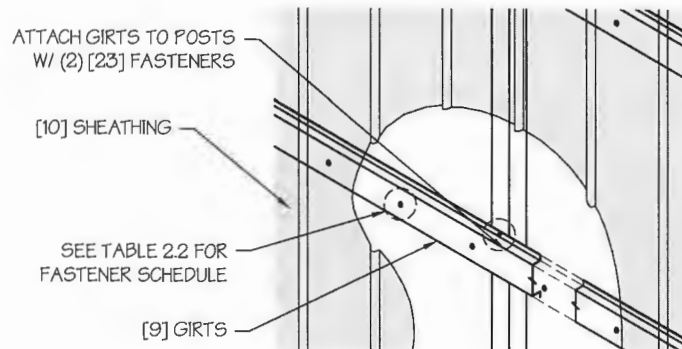

□ WALL VERTICAL SHEATHING - HAT CHANNEL DETAIL 3
SCALE: NTS

MANUFACTURED BY:



DRAWING INFORMATION

PROJECT: 22'-0" WIDE BUILDINGS
LOCATION: STATE OF MICHIGAN
PROJECT NO.: 451-22-1572
SHEET TITLE:

SHEATHING OPTIONS & DETAILS

SHEET NO.: 6 / 11
DRAWN BY: AW DATE: 5/17/22
CHECKED BY: OAA DATE: 5/17/22

LEGAL INFORMATION

- ANY DUPLICATION OF THIS DRAWING IN WHOLE OR PART IS STRICTLY FORBIDDEN. ANYONE DOING SO WILL BE PROSECUTED UNDER THE FULL EXTENT OF THE LAW.
- DRAWINGS VALID UP TO 1 YEAR FROM DATE OF ISSUE.

SEAL:

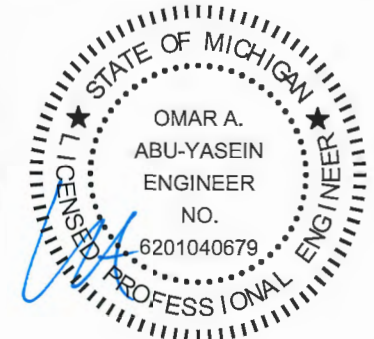

DATE EXPIRES: **03-24-2024**
DATE SIGNED: **05-20-2022**

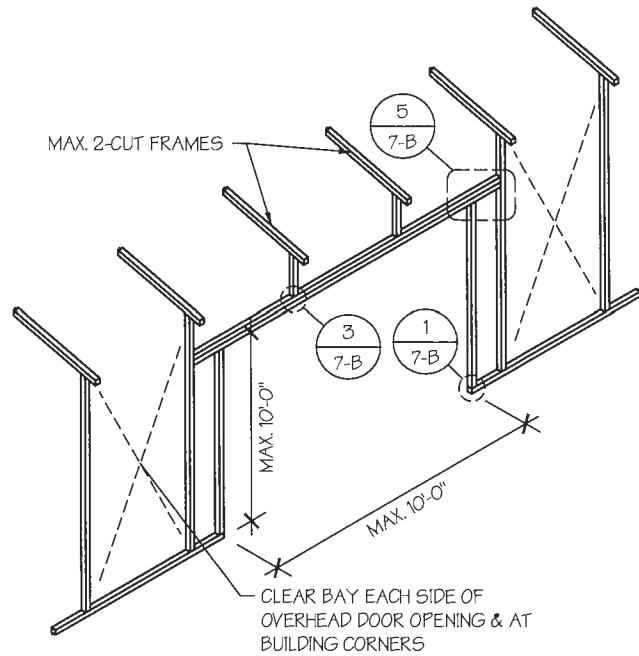

SIDE WALL OVERHEAD DOOR OPENINGS
SCALE: NTS

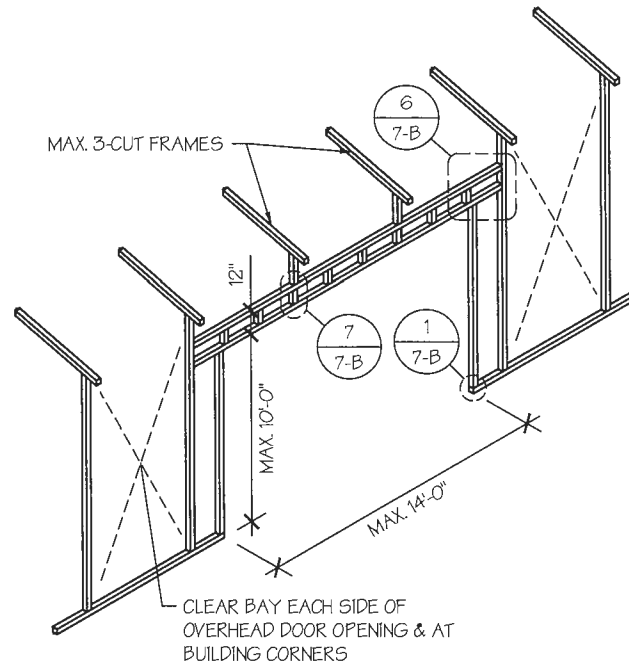

SIDE WALL OVERHEAD DOOR OPENINGS WITH TRUSS STYLE HEADER
SCALE: NTS

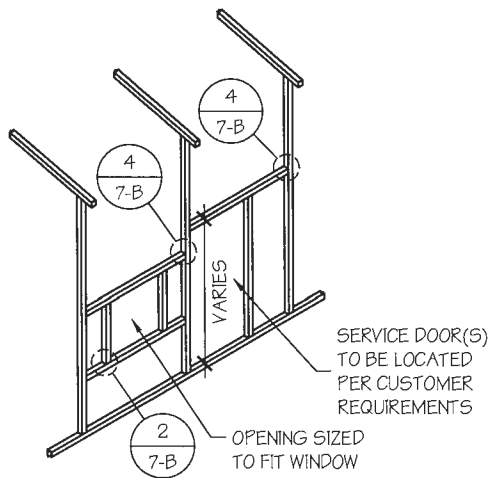

SIDE WALL SERVICE DOOR / WINDOW OPENINGS
SCALE: NTS

SIDE WALL FRAMING NOTES:

1. TRUSS-STYLE HEADERS ARE REQUIRED FOR WHERE THE GROUND SNOW LOAD IS 40 PSF OR GREATER.
2. DESIGNS AND DETAILS SHOWN HERE ARE APPLICABLE TO BOTH REGULAR AND A-FRAME STYLE BUILDINGS.
3. MAX. HEIGHT OF SIDE WALL OVERHEAD DOOR OPENINGS IS 2 FT LESS THAN THE EAVE HEIGHT.
4. OVERHEAD DOOR OPENINGS CANNOT CUT THROUGH MORE THAN 2 FULL FRAMES.
5. MIN. 1 CLEAR BAY MUST BE MAINTAINED BETWEEN ANY 2 OVERHEAD DOOR OPENINGS. A CLEAR BAY IS A SPACE BETWEEN TWO FRAMES THAT HAS NO OVERHEAD DOOR OPENINGS.
6. MIN. 1 CLEAR BAY MUST ALSO BE MAINTAINED FROM THE BUILDING CORNERS.
7. SERVICE DOORS AND WINDOWS CAN BE PLACED IN CLEAR BAYS OR ANY WHERE ELSE AS NEEDED.

MANUFACTURED BY:



DRAWING INFORMATION

PROJECT: 22'-0" WIDE BUILDINGS

LOCATION: STATE OF MICHIGAN

PROJECT NO.: 451-22-1572

SHEET TITLE:

SIDE WALL FRAMING
& OPENINGS

SHEET NO.: 7-A / 11

DRAWN BY: AW DATE: 5/17/22

CHECKED BY: OAA DATE: 5/17/22

LEGAL INFORMATION

- ANY DUPLICATION OF THIS DRAWING IN WHOLE OR PART IS STRICTLY FORBIDDEN. ANYONE DOING SO WILL BE PROSECUTED UNDER THE FULL EXTENT OF THE LAW.
- DRAWINGS VALID UP TO 1 YEAR FROM DATE OF ISSUE.

SEAL:

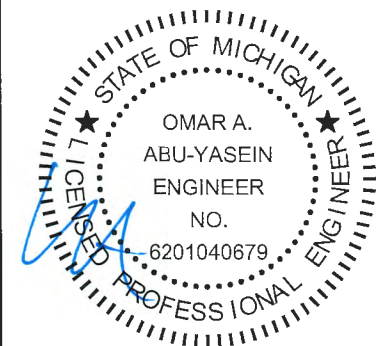

DATE EXPIRES: **03-24-2024**

DATE SIGNED: **05-20-2022**

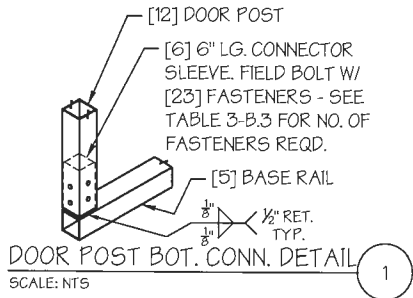

DOOR POST BOT. CONN. DETAIL
SCALE: NTS

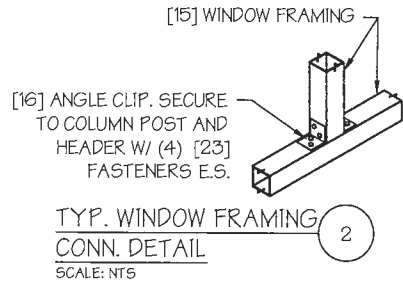

TYP. WINDOW FRAMING CONN. DETAIL
SCALE: NTS

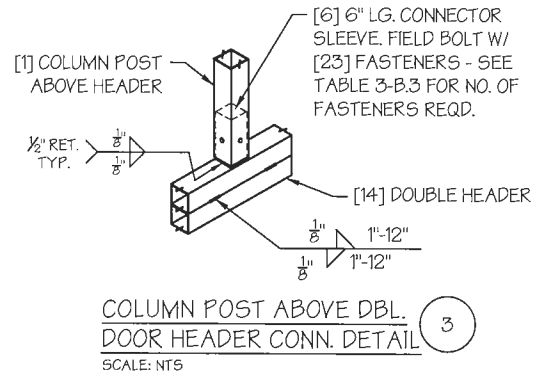

COLUMN POST ABOVE DBL. DOOR HEADER CONN. DETAIL
SCALE: NTS

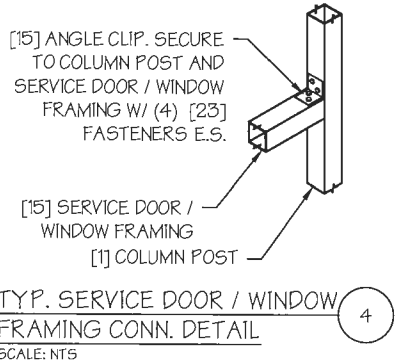

TYP. SERVICE DOOR / WINDOW FRAMING CONN. DETAIL
SCALE: NTS

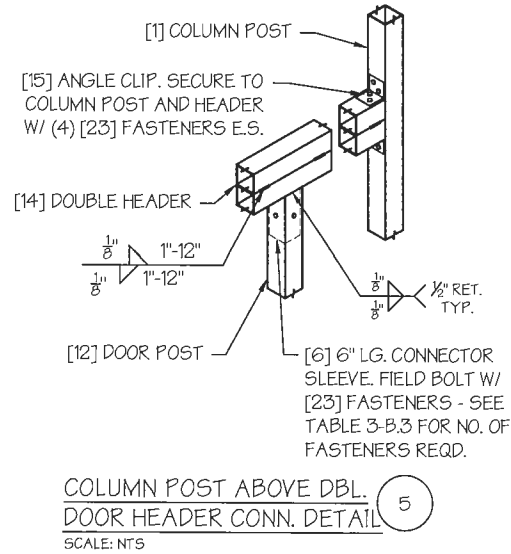

COLUMN POST ABOVE DBL. DOOR HEADER CONN. DETAIL
SCALE: NTS

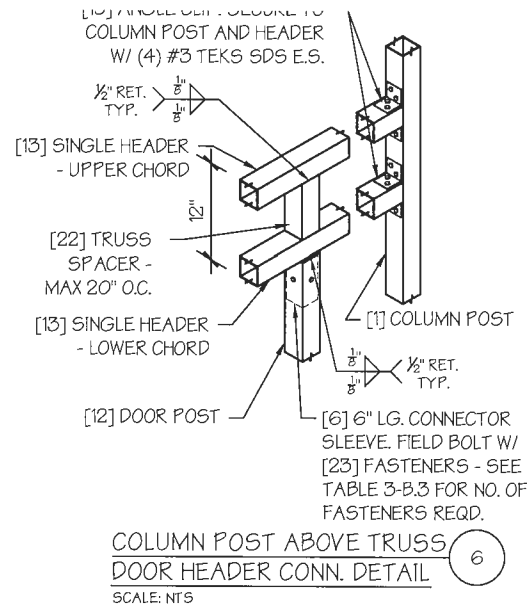

COLUMN POST ABOVE TRUSS DOOR HEADER CONN. DETAIL
SCALE: NTS

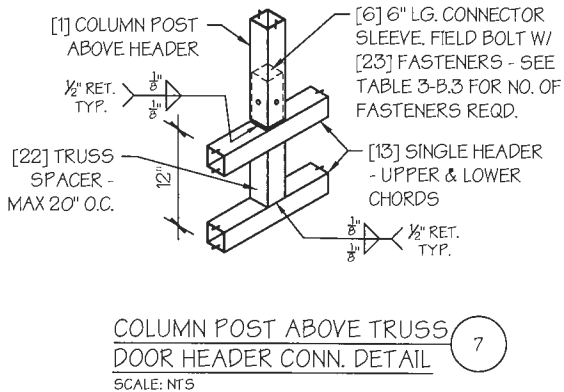

COLUMN POST ABOVE TRUSS DOOR HEADER CONN. DETAIL
SCALE: NTS

MANUFACTURED BY:



DRAWING INFORMATION	
PROJECT:	22'-0" WIDE BUILDINGS
LOCATION:	STATE OF MICHIGAN
PROJECT NO.:	451-22-1572
SHEET TITLE:	SIDE WALL FRAMING DETAILS
SHEET NO.:	7-B / 11
DRAWN BY:	AW DATE: 5/17/22
CHECKED BY:	OAA DATE: 5/17/22

LEGAL INFORMATION
- ANY DUPLICATION OF THIS DRAWING IN WHOLE OR PART IS STRICTLY FORBIDDEN. ANYONE DOING SO WILL BE PROSECUTED UNDER THE FULL EXTENT OF THE LAW.
- DRAWINGS VALID UP TO 1 YEAR FROM DATE OF ISSUE.

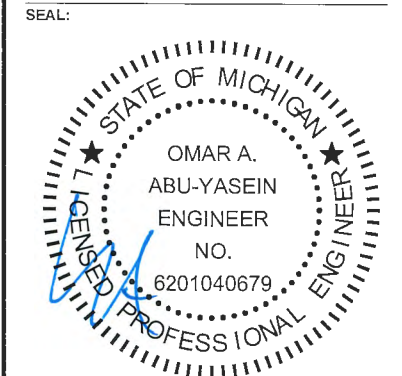

DATE EXPIRES: **03-24-2024**
DATE SIGNED: **05-20-2022**

MANUFACTURED BY:

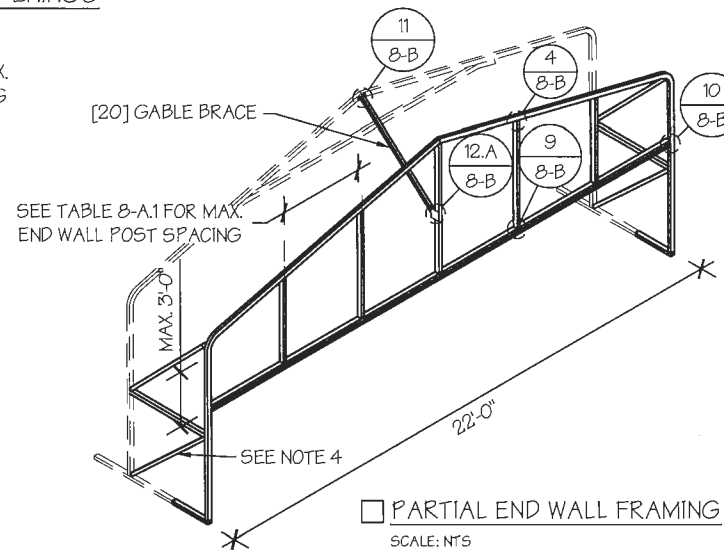
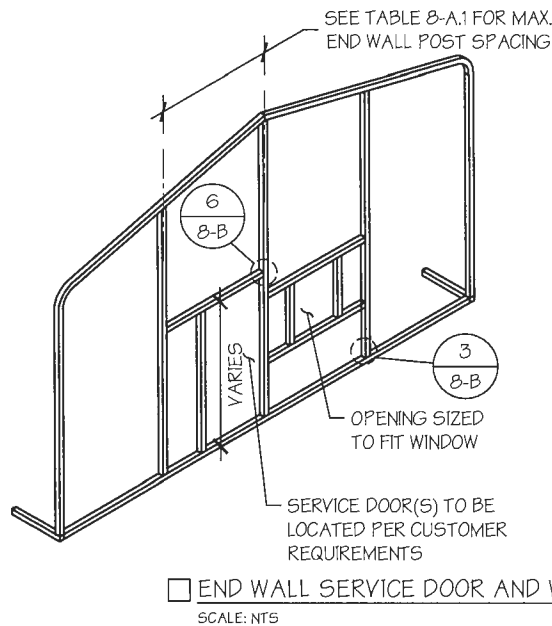
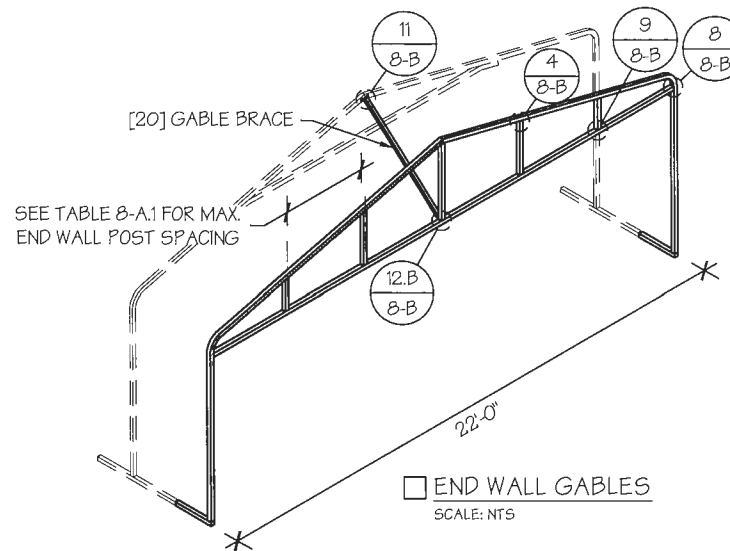
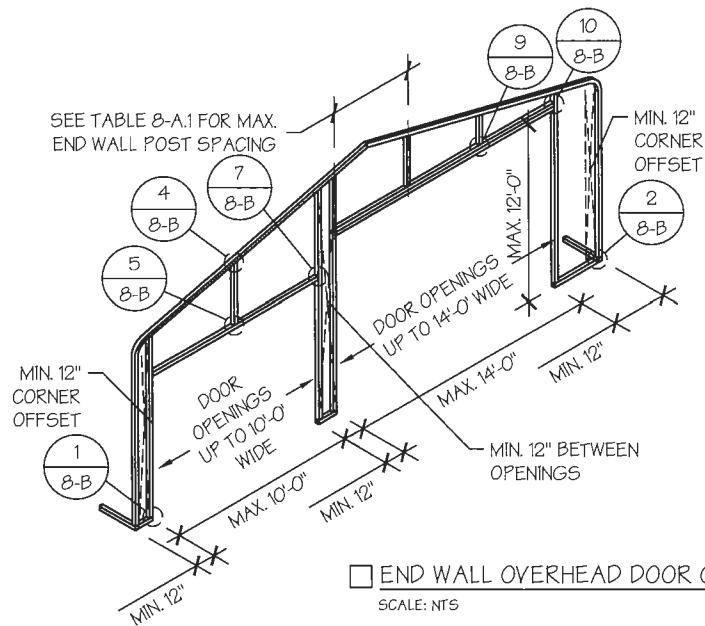

END WALL FRAMING NOTES:

- DESIGNS AND DETAILS SHOWN HERE ARE APPLICABLE TO BOTH REGULAR AND A-FRAME STYLE BUILDINGS.
- MIN. 12" CLEARANCE MUST BE MAINTAINED BETWEEN ANY TWO OPENINGS (OVERHEAD DOOR OR SERVICE DOOR) AND FROM CORNERS.
- SERVICE DOORS AND WINDOWS CAN BE PLACED AS NEEDED.
- DIAGONAL BRACES NEED TO BE ADDED FOR PARTIAL END WALL ENCLOSURES. SEE SHEET 9 FOR DIAGONAL BRACE CONNECTION DETAILS.

TABLE 8-A.1: END WALL POST SPACING SCHEDULE

WIND SPEED (MPH)	EAVE HEIGHT		
	UP TO 7'	8' TO 9'	10' TO 12'
105	5'	5'	5'
115	5'	5'	4.5'
130	4.5'	4.5'	4'
140	4.5'	4.5'	3'
155	4'	4'	2.5'
165 - 180	3.5'	3'	2'

DRAWING INFORMATION

PROJECT: 22'-0" WIDE BUILDINGS
 LOCATION: STATE OF MICHIGAN
 PROJECT NO.: 451-22-1572
 SHEET TITLE:

END WALL FRAMING

SHEET NO.: 8-A / 11
 DRAWN BY: AW DATE: 5/17/22
 CHECKED BY: OAA DATE: 5/17/22

LEGAL INFORMATION

- ANY DUPLICATION OF THIS DRAWING IN WHOLE OR PART IS STRICTLY FORBIDDEN. ANYONE DOING SO WILL BE PROSECUTED UNDER THE FULL EXTENT OF THE LAW. - DRAWINGS VALID UP TO 1 YEAR FROM DATE OF ISSUE.

SEAL:

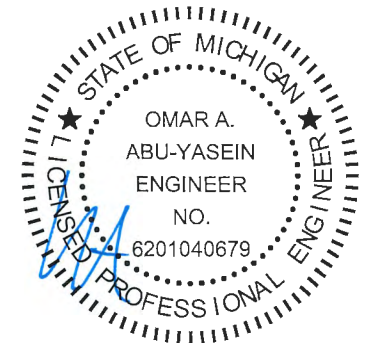

DATE EXPIRES: 03-24-2024
 DATE SIGNED: 05-20-2022

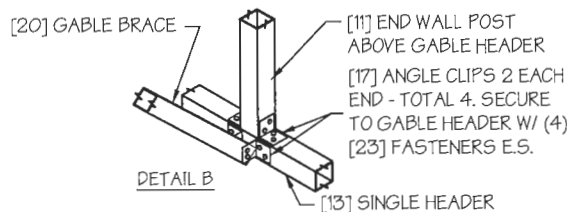
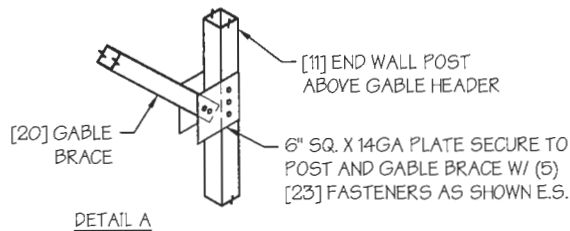
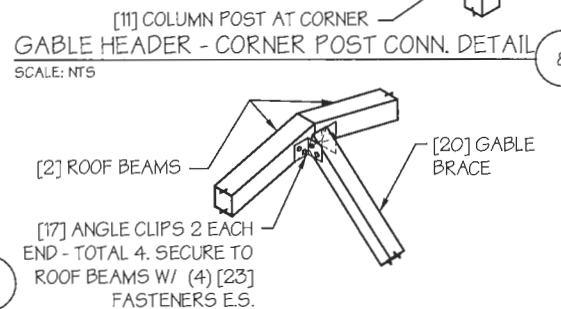
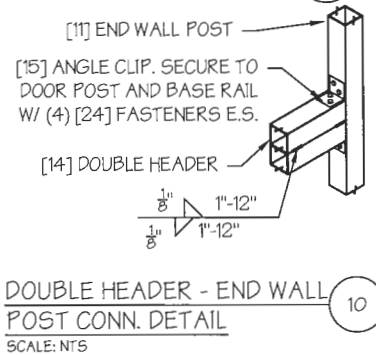
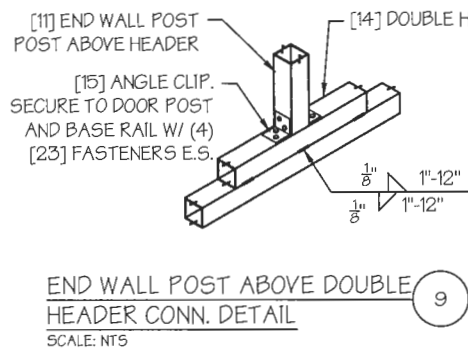
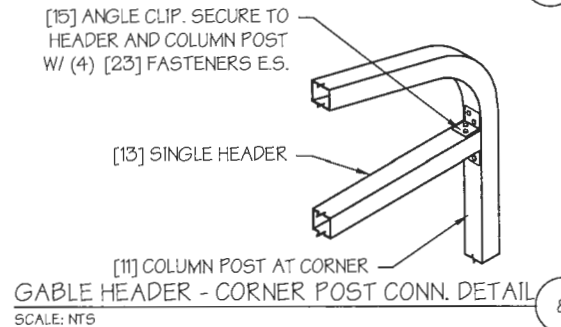
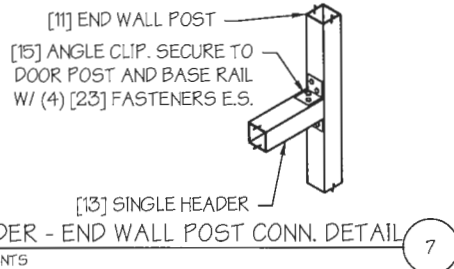
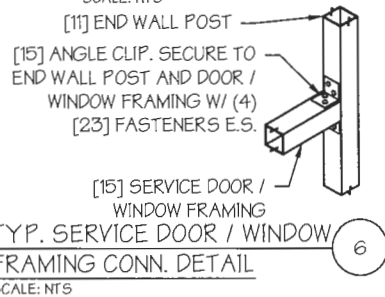
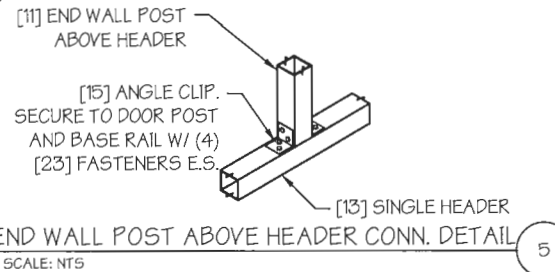
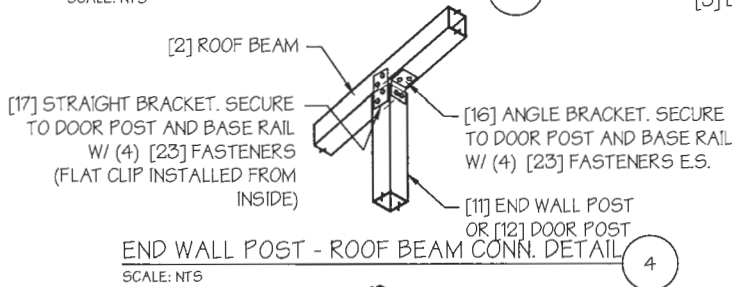
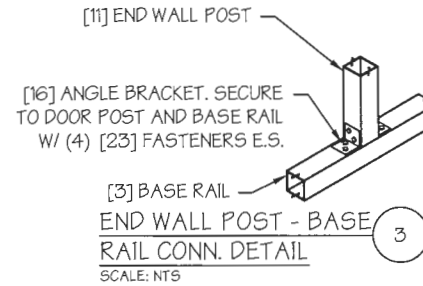
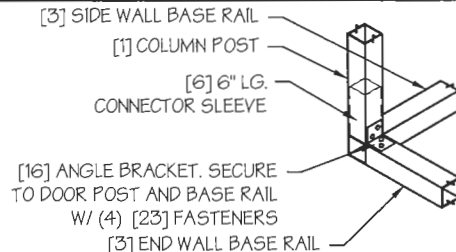
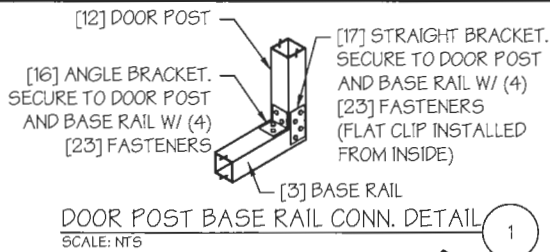

GABLE BRACE - END WALL CONN. DETAIL
SCALE: NTS

MANUFACTURED BY:



DRAWING INFORMATION

PROJECT: 22'-0" WIDE BUILDINGS

LOCATION: STATE OF MICHIGAN

PROJECT NO.: 451-22-1572

SHEET TITLE:

END WALL FRAMING
DETAILS

SHEET NO.: 8-B / 11

DRAWN BY: AW DATE: 5/17/22

CHECKED BY: OAA DATE: 5/17/22

LEGAL INFORMATION

- ANY DUPLICATION OF THIS DRAWING IN WHOLE OR PART IS STRICTLY FORBIDDEN. ANYONE DOING SO WILL BE PROSECUTED UNDER THE FULL EXTENT OF THE LAW.
- DRAWINGS VALID UP TO 1 YEAR FROM DATE OF ISSUE.

SEAL:

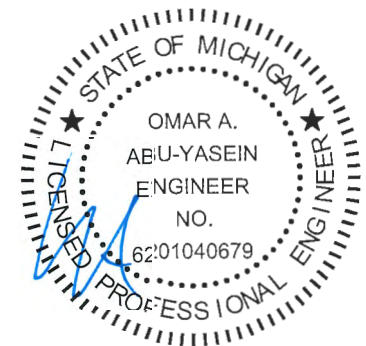

DATE EXPIRES: 03-24-2024

DATE SIGNED: 05-20-2022

MANUFACTURED BY:

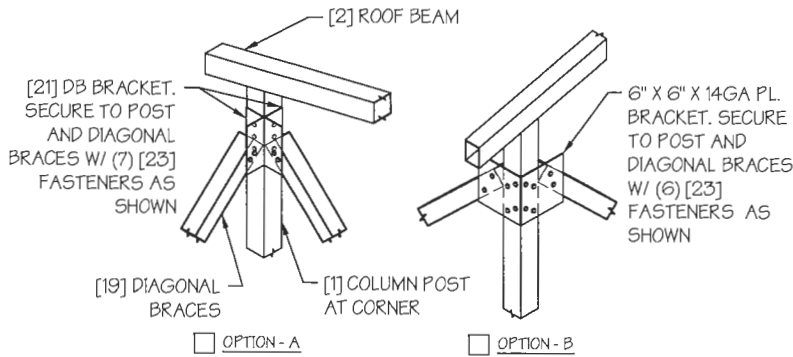

DIAGONAL BRACE TOP CORNER CONN. DETAIL* 1

SCALE: NTS

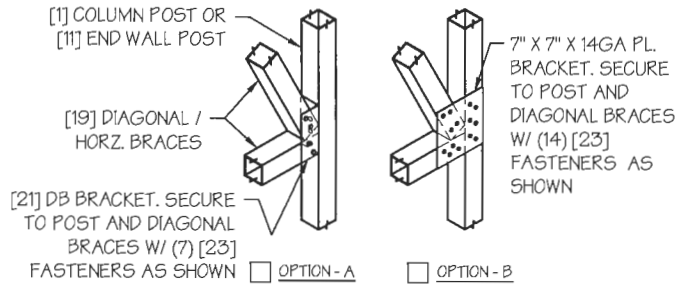

DIAGONAL BRACE - POST CONN. DETAIL* 2

SCALE: NTS

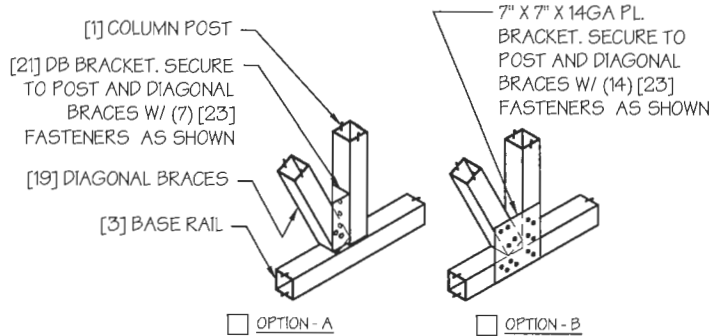

DIAGONAL BRACE BOT. CORNER CONN. DETAIL* 3

SCALE: NTS

* INSIDE VIEW SHOWN FOR CLARITY

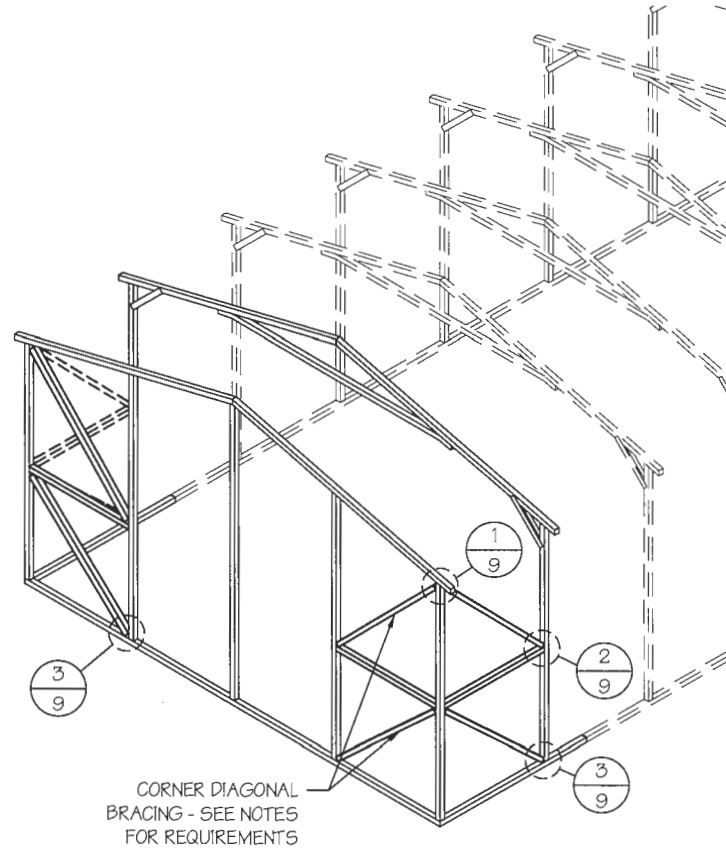

DIAGONAL BRACING AT CORNERS

SCALE: NTS

CORNER BRACING NOTES:

- DIAGONAL BRACING AT BUILDING CORNERS IS REQUIRED FOR ALL BUILDINGS IN LOCATIONS WHERE WIND SPEED IS 140 MPH OR GREATER.
 - FOR 3 SIDED ENCLOSED BUILDINGS 140 MPH OR GREATER WIND SPEED - THE BUILDING MUST BE DESIGNED WITH OPEN BUILDING SPACING AND DIAGONAL BRACING IS REQUIRED ON ALL ENCLOSED WALLS.
- SIDE-WALL DIAGONAL BRACING IS REQUIRED WHEN THE ADJACENT END-WALL IS PARTIALLY ENCLOSED.
- ALL BUILDINGS WITH IRREGULAR ENCLOSURE (SEE SHEET 5) WILL REQUIRE SIDE-WALL BRACING CLOSE TO THE PARTIALLY ENCLOSED END-WALL.

DRAWING INFORMATION

PROJECT: 22'-0" WIDE BUILDINGS

LOCATION: STATE OF MICHIGAN

PROJECT NO.: 451-22-1572

SHEET TITLE:

CORNER BRACING DETAILS

SHEET NO.: 9 / 11

DRAWN BY: AW DATE: 5/17/22

CHECKED BY: OAA DATE: 5/17/22

LEGAL INFORMATION

- ANY DUPLICATION OF THIS DRAWING IN WHOLE OR PART IS STRICTLY FORBIDDEN. ANYONE DOING SO WILL BE PROSECUTED UNDER THE FULL EXTENT OF THE LAW. - DRAWINGS VALID UP TO 1 YEAR FROM DATE OF ISSUE.

SEAL:

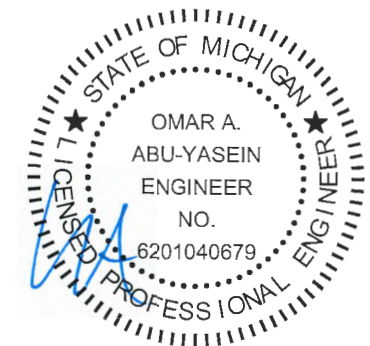

DATE EXPIRES: 03-24-2024

DATE SIGNED: 05-20-2022

MANUFACTURED BY:



DRAWING INFORMATION

PROJECT: 22'-0" WIDE BUILDINGS

LOCATION: STATE OF MICHIGAN

PROJECT NO.: 451-22-1572

SHEET TITLE:

OPTIONAL LEAN-TO
ADDITION

SHEET NO.: 10 / 11

DRAWN BY: AW DATE: 5/17/22

CHECKED BY: OAA DATE: 5/17/22

LEGAL INFORMATION

- ANY DUPLICATION OF THIS DRAWING IN WHOLE OR PART IS STRICTLY FORBIDDEN. ANYONE DOING SO WILL BE PROSECUTED UNDER THE FULL EXTENT OF THE LAW.
- DRAWINGS VALID UP TO 1 YEAR FROM DATE OF ISSUE.

SEAL:

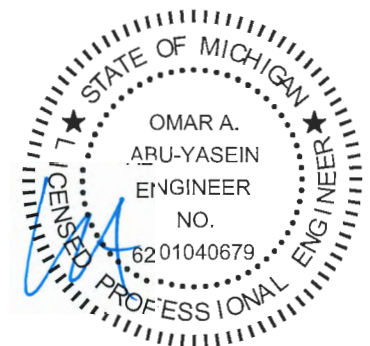

DATE EXPIRES: **03-24-2024**

DATE SIGNED: **05-20-2022**

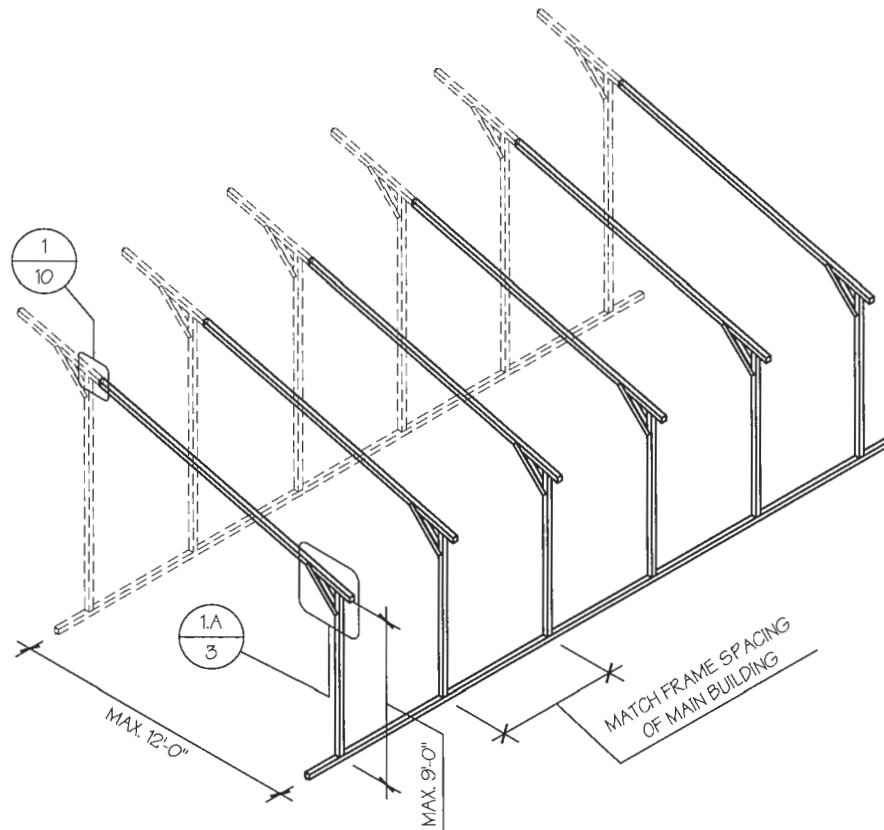

OPTIONAL LEAN-TO ADDITION

SCALE: NTS

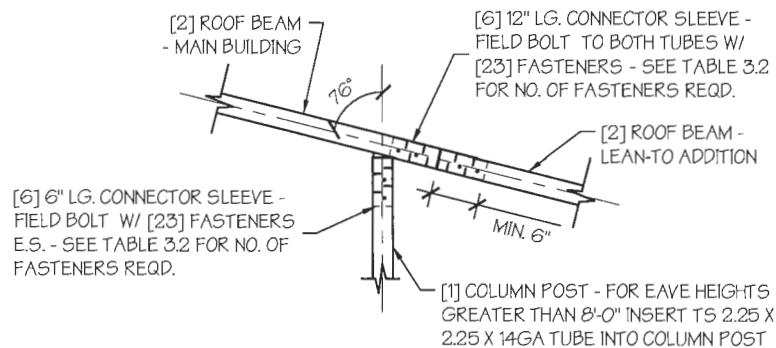

LEAN-TO ATTACHMENT DETAIL 1
SCALE: NTS

LEAN-TO ADDITION NOTES:

- LEAN-TO ADDITIONS CAN BE ADDED ON EITHER OR BOTH SIDES OF THE BUILDING.
- ROOF SLOPE, PURLIN, GIRT AND FRAME SPACING OF THE ADDITION HAVE TO MATCH THAT OF THE MAIN STRUCTURE.
- IF THE LEAN-TO ADDITION IS "OPEN" (BOTH END WALLS OR SIDE WALL IS NOT ENCLOSED), THE DESIGN OF THE MAIN BUILDING HAS TO USE THE FRAME SPACING OF AN OPEN BUILDING FROM TABLE 4.

CONCRETE SLAB FOUNDATION NOTES:

- DESIGNS SHOWN ON THIS SHEET ARE FOR CONCRETE SLAB FOUNDATION. ANY OF THE FOUNDATIONS SHOWN ON SHEETS 11-A THRU C CAN BE USED.
- CONCRETE ANCHORS SHALL BE LOCATED NEXT TO EVERY POST AND ON EITHER SIDE OF OPENINGS. TWO ANCHORS SHALL BE INSTALLED AT CORNERS OF ENCLOSED BUILDINGS WITH END WALLS - ONE ON EACH BASE RAIL. IN LOCATIONS REQUIRING TWO ANCHORS DUE TO WIND, ONE ANCHOR IS TO BE ON EACH SIDE OF THE COLUMN POST.
- ANCHORS IN CLOSE PROXIMITY TO EACH OTHER MUST HAVE A MIN. 4" SPACING.
- MIN. NUMBER OF CONCRETE ANCHORS PER POST SHALL BE AS SHOWN IN TABLE 11-A.2.
- THE SIZE OF THE SLAB SHALL BE THE SIZE (WIDTH AND LENGTH) OF THE BUILDING PLUS $5\frac{1}{2}$ " FOR 14GA MATERIAL AND $5\frac{3}{4}$ " FOR 12GA MATERIAL.
- DEPTH OF SLAB TURN DOWN FOOTING SHALL BE GREATER THAN FROST DEPTH SPECIFIED PER LOCAL CODE.
- CONTROL JOINTS SHALL BE PLACED SO AS TO LIMIT MAX. SLAB SPANS TO 20' IN EACH DIRECTION.
- ASSUMED SOIL BEARING CAPACITY IS TO BE A MIN. OF 1500 PSF.
- CONCRETE STRENGTH TO BE A MIN OF 2500 PSI @ 28 DAYS.

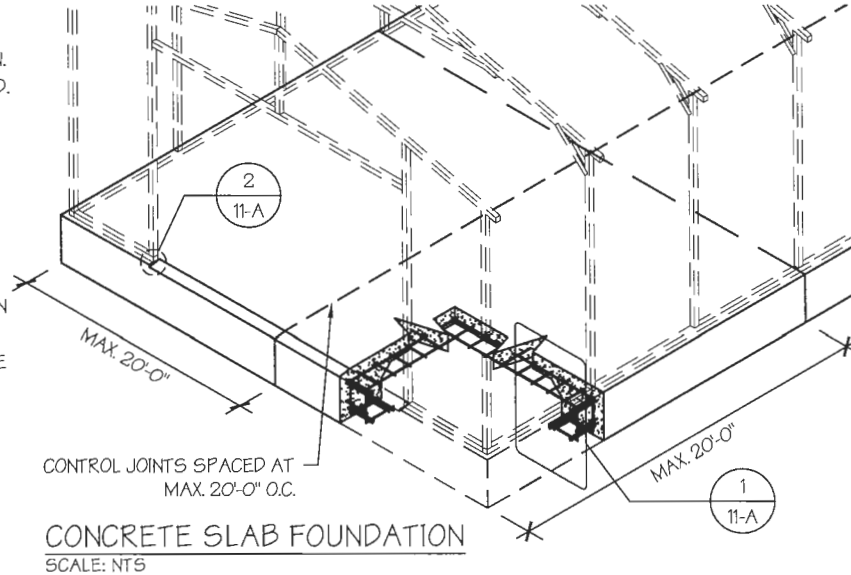

MANUFACTURED BY:



DRAWING INFORMATION

PROJECT: 22'-0" WIDE BUILDINGS

LOCATION: STATE OF MICHIGAN

PROJECT NO.: 451-22-1572

SHEET TITLE:

FOUNDATION OPTION 1:
CONCRETE SLAB

SHEET NO.: 11-A / 11

DRAWN BY: AW DATE: 5/17/22

CHECKED BY: OAA DATE: 5/17/22

LEGAL INFORMATION

- ANY DUPLICATION OF THIS DRAWING IN WHOLE OR PART IS STRICTLY FORBIDDEN. ANYONE DOING SO WILL BE PROSECUTED UNDER THE FULL EXTENT OF THE LAW.
- DRAWINGS VALID UP TO 1 YEAR FROM DATE OF ISSUE.

SEAL:

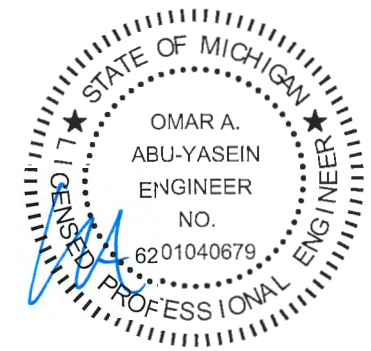

DATE EXPIRES: **03-24-2024**

DATE SIGNED: **05-20-2022**

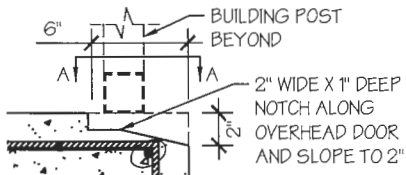

OVERHEAD DOOR NOTCH DETAIL
SCALE: NTS

TABLE 11-A.2: CONCRETE SLAB ANCHOR SCHEDULE

ENCLOSURE	WIND SPEED (MPH)	ANCHOR SIZE/NUMBER
ENCLOSED	105 TO 135	(1) 1/2" Ø X 7"
	136 TO 180	(2) 1/2" Ø X 7"
OPEN	105 TO 135	(1) 1/2" Ø X 7"
	136 TO 180	(2) 1/2" Ø X 7"

NOTES:

- ANCHORS ARE TO BE CONCRETE WEDGE OR EXPANSION ANCHORS.
- MIN. EMBEDMENT DEPTH TO BE 2 7/8".
- ANCHORS TO BE SPACED NO MORE THAN 6" FROM POSTS.

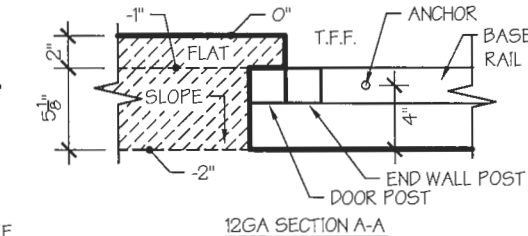
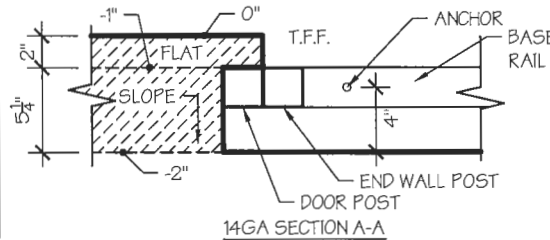
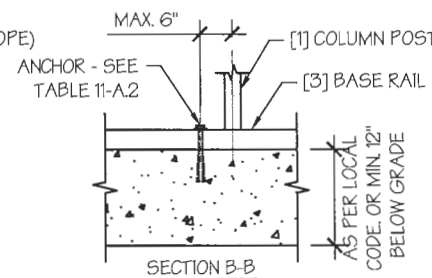
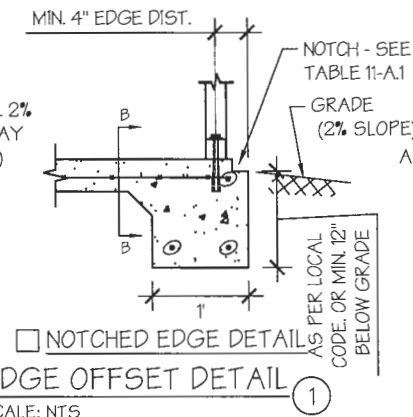
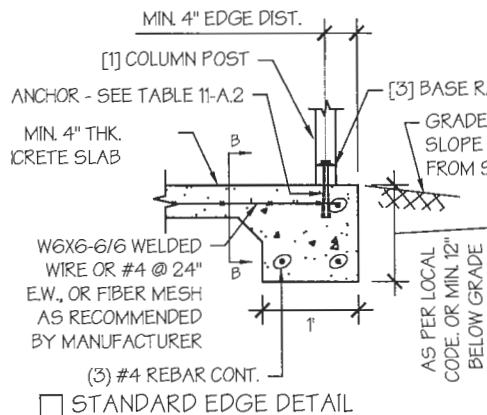

TABLE 11-A.1: NOTCH WIDTH

HORIZONTAL/OPEN		VERTICAL	
14GA	12GA	14GA	12GA
2 3/4"	2 7/8"	1 3/4"	1 7/8"

NOTE: DEPTH IS TO BE 1 1/2"



EDGE OFFSET DETAIL
SCALE: NTS

CONCRETE SLAB FOUNDATION NOTES:

- DESIGNS SHOWN ON THIS SHEET ARE FOR CONCRETE SLAB FOUNDATION. ANY OF THE FOUNDATIONS SHOWN ON SHEETS 11-A THRU C CAN BE USED.
- CONCRETE ANCHORS SHALL BE LOCATED NEXT TO EVERY POST AND ON EITHER SIDE OF OPENINGS. TWO ANCHORS SHALL BE INSTALLED AT CORNERS OF ENCLOSED BUILDINGS WITH END WALLS - ONE ON EACH BASE RAIL. IN LOCATIONS REQUIRING TWO ANCHORS DUE TO WIND, ONE ANCHOR IS TO BE ON EACH SIDE OF THE COLUMN POST.
- ANCHORS IN CLOSE PROXIMITY TO EACH OTHER MUST HAVE A MIN. 4" SPACING.
- MIN. NUMBER OF CONCRETE ANCHORS PER POST SHALL BE AS SHOWN IN TABLE 11-A.1.
- THE SIZE OF THE SLAB SHALL BE THE SIZE (WIDTH AND LENGTH) OF THE BUILDING PLUS 1/2" FOR 14GA MATERIAL AND 1" FOR 12GA MATERIAL.
- DEPTH OF SLAB TURN DOWN FOOTING SHALL BE GREATER THAN FROST DEPTH SPECIFIED PER LOCAL CODE.
- CONTROL JOINTS SHALL BE PLACED SO AS TO LIMIT MAX. SLAB SPANS TO 20' IN EACH DIRECTION.
- ASSUMED SOIL BEARING CAPACITY IS TO BE A MIN. OF 1500 PSF.
- CONCRETE STRENGTH TO BE A MIN OF 2500 PSI @ 28 DAYS.

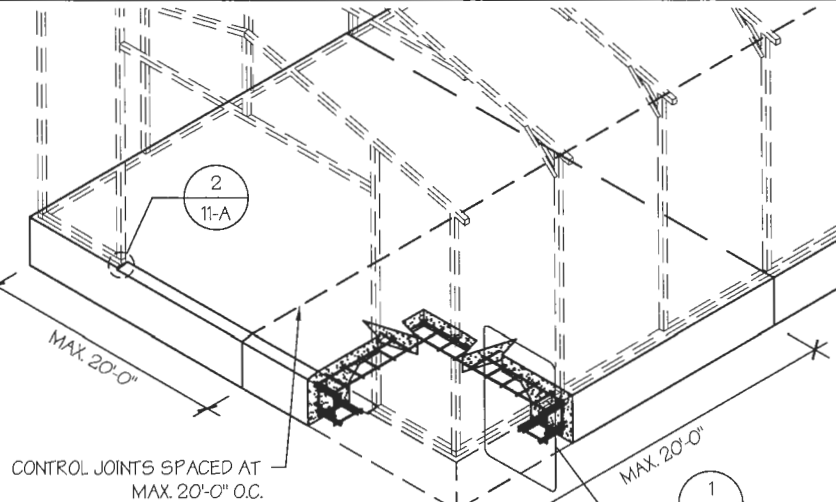

CONCRETE SLAB FOUNDATION

SCALE: NTS

TABLE 11-A.1: CONCRETE SLAB ANCHOR SCHEDULE

ENCLOSURE	WIND SPEED (MPH)	ANCHOR SIZE/NUMBER
ENCLOSED	□ 105 TO 135	(1) 1/2"Ø X 7"
	□ 136 TO 180	(2) 1/2"Ø X 7"
OPEN	□ 105 TO 135	(1) 1/2"Ø X 7"
	□ 136 TO 180	(2) 1/2"Ø X 7"

NOTES:

- ANCHORS ARE TO BE CONCRETE WEDGE OR EXPANSION ANCHORS.
- MIN. EMBEDMENT DEPTH TO BE 2 2/3".
- ANCHORS TO BE SPACED NO MORE THAN 6" FROM POSTS.

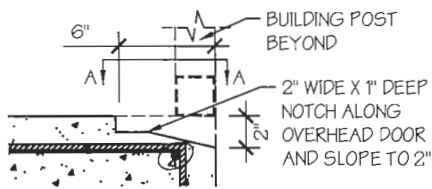

OVERHEAD DOOR NOTCH DETAIL

SCALE: NTS

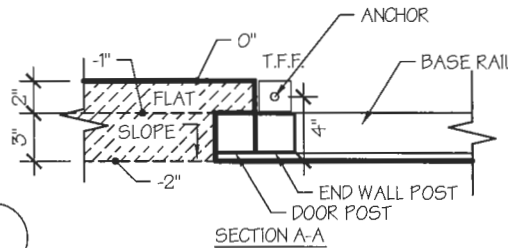

SECTION A-A

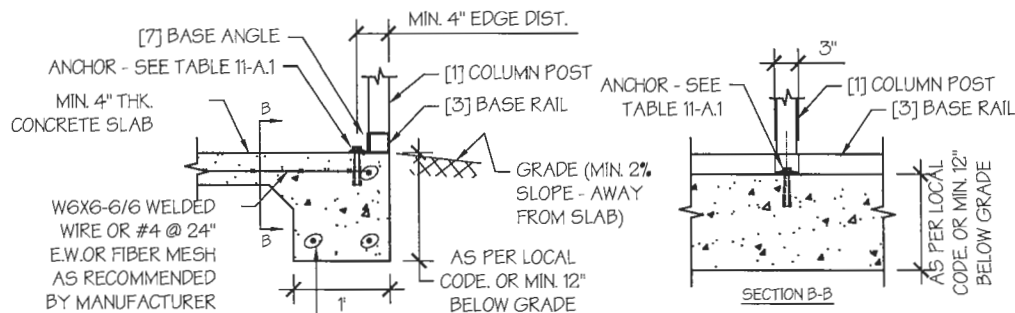

EDGE FLUSH DETAIL

SCALE: NTS

MANUFACTURED BY:



DRAWING INFORMATION

PROJECT: 22'-0" WIDE BUILDINGS

LOCATION: STATE OF MICHIGAN

PROJECT NO.: 451-22-1572

SHEET TITLE:

FOUNDATION OPTION 1:
CONCRETE SLAB

SHEET NO.: 11-A / 11

DRAWN BY: AW DATE: 5/17/22

CHECKED BY: OAA DATE: 5/17/22

LEGAL INFORMATION

- ANY DUPLICATION OF THIS DRAWING IN WHOLE OR PART IS STRICTLY FORBIDDEN. ANYONE DOING SO WILL BE PROSECUTED UNDER THE FULL EXTENT OF THE LAW.
- DRAWINGS VALID UP TO 1 YEAR FROM DATE OF ISSUE.

SEAL:

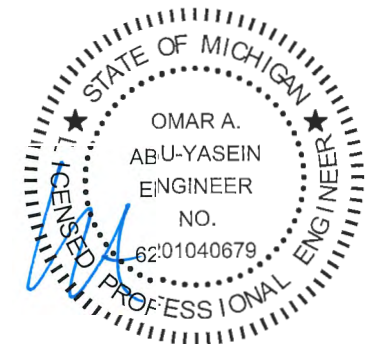

DATE EXPIRES: **03-24-2024**

DATE SIGNED: **05-20-2022**

TABLE 11-B.1: ANCHOR SCHEDULE

ENCLOSURE	WIND SPEED (MPH)	ANCHOR SIZE/NUMBER
ENCLOSED	□ 105 TO 135	(1) 1/2"Ø X 7"
	□ 136 TO 180	(2) 1/2"Ø X 7"
OPEN	□ 105 TO 135	(1) 1/2"Ø X 7"
	□ 136 TO 180	(2) 1/2"Ø X 7"

NOTES:

1. ANCHORS ARE TO BE CONCRETE WEDGE OR EXPANSION ANCHORS.
2. MIN. EMBEDMENT DEPTH TO BE 2 7/8".
3. ANCHORS TO BE SPACED NO MORE THAN 6" FROM POSTS.

TABLE 11-B.2: CONC. STRIP SCHEDULE

WIND SPEED (MPH)	MIN. SIZE REQD.
□ 105 TO 130	12" X 12"
□ 140 TO 155	18" X 12"
□ 165 TO 180	26" X 12"
	21 X 15"
	18" X 18"

NOTES:

1. WIDTH AND DEPTH DIMENSIONS CAN BE INTERCHANGED.

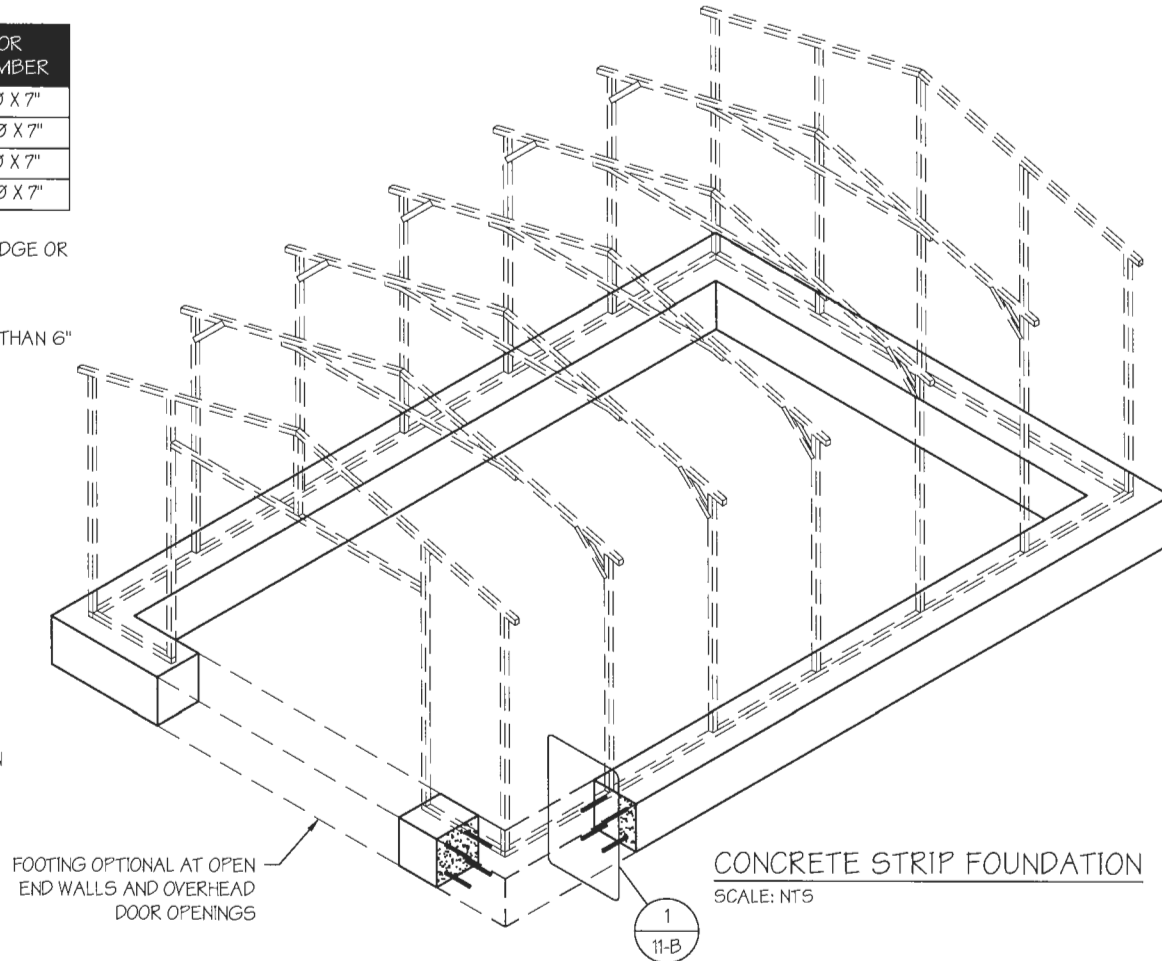

FOOTING OPTIONAL AT OPEN END WALLS AND OVERHEAD DOOR OPENINGS

CONCRETE STRIP FOUNDATION
SCALE: NTS

CONCRETE STRIP FOUNDATION NOTES:

1. DESIGNS SHOWN ON THIS SHEET ARE FOR CONCRETE STRIP FOUNDATION. ANY OF THE FOUNDATIONS SHOWN ON SHEETS 11-A THRU C CAN BE USED.
2. CONCRETE ANCHORS SHALL BE LOCATED NEXT TO EVERY POST AND ON EITHER SIDE OF OPENINGS. TWO ANCHORS SHALL BE INSTALLED AT CORNERS OF ENCLOSED BUILDINGS WITH END WALLS - ONE ON EACH BASE RAIL. IN LOCATIONS REQUIRING TWO ANCHORS DUE TO WIND, ONE ANCHOR IS TO BE ON EACH SIDE OF THE COLUMN POST.
3. MIN. NUMBER OF CONCRETE ANCHORS PER POST SHALL BE AS SHOWN IN TABLE 11-B.1.
4. ANCHORS IN CLOSE PROXIMITY TO EACH OTHER MUST HAVE A MIN. 4" SPACING.
5. DEPTH OF CONCRETE STRIP FOOTING SHALL BE GREATER THAN FROST DEPTH SPECIFIED PER LOCAL CODE.
6. ASSUMED SOIL BEARING CAPACITY IS TO BE A MIN. OF 1500 PSF.
7. CONCRETE STRENGTH TO BE A MIN OF 2500 PSI @ 28 DAYS.
8. BUILDING IS TO BE MOUNTED ON THE CENTER OF THE STRIP FOUNDATION.

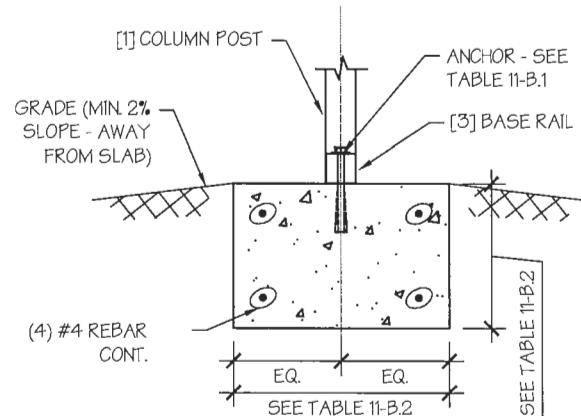

CONCRETE STRIP FOUNDATION DETAIL
SCALE: NTS

MANUFACTURED BY:



DRAWING INFORMATION

PROJECT: 22'-0" WIDE BUILDINGS

LOCATION: STATE OF MICHIGAN

PROJECT NO.: 451-22-1572

SHEET TITLE:

FOUNDATION OPTION 2:
CONCRETE STRIP

SHEET NO.: 11-B / 11

DRAWN BY: AW DATE: 5/17/22

CHECKED BY: OAA DATE: 5/17/22

LEGAL INFORMATION

- ANY DUPLICATION OF THIS DRAWING IN WHOLE OR PART IS STRICTLY FORBIDDEN. ANYONE DOING SO WILL BE PROSECUTED UNDER THE FULL EXTENT OF THE LAW.
- DRAWINGS VALID UP TO 1 YEAR FROM DATE OF ISSUE.

SEAL:

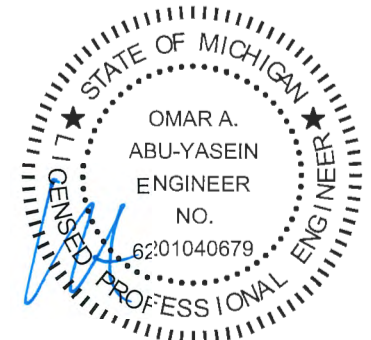

DATE EXPIRES: 03-24-2024

DATE SIGNED: 05-20-2022

MANUFACTURED BY:



DRAWING INFORMATION

PROJECT: 22'-0" WIDE BUILDINGS

LOCATION: STATE OF MICHIGAN

PROJECT NO.: 451-22-1572

SHEET TITLE:

FOUNDATION OPTION 3:
CONCRETE PIERS

SHEET NO.: 11-C / 11

DRAWN BY: AW DATE: 5/17/22

CHECKED BY: OAA DATE: 5/17/22

LEGAL INFORMATION

- ANY DUPLICATION OF THIS DRAWING IN WHOLE OR PART IS STRICTLY FORBIDDEN. ANYONE DOING SO WILL BE PROSECUTED UNDER THE FULL EXTENT OF THE LAW.
- DRAWINGS VALID UP TO 1 YEAR FROM DATE OF ISSUE.

SEAL:

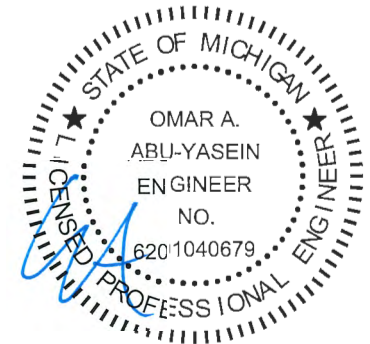

DATE EXPIRES: **03-24-2024**

DATE SIGNED: **05-20-2022**

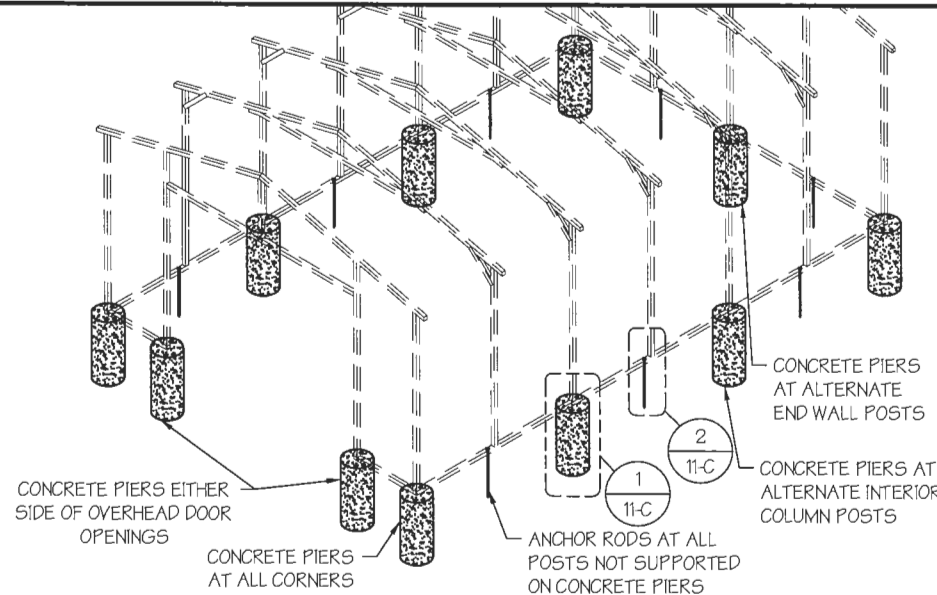

CONCRETE PIER FOUNDATION

SCALE: NTS

CONCRETE PIER FOUNDATION NOTES:

- DESIGNS SHOWN ON THIS SHEET ARE FOR CONCRETE PIER FOUNDATION. ANY OF THE FOUNDATIONS SHOWN ON SHEETS 11-A THRU C CAN BE USED.
- CONCRETE PIERS SHALL BE LOCATED AT ALL 4 CORNERS, ON EACH SIDE OF OVERHEAD DOOR OPENINGS AND ON ALTERNATE INTERIOR COLUMN POSTS AND END WALLS POSTS.
- TWO ANCHORS SHALL BE INSTALLED AT CORNERS OF ENCLOSED BUILDINGS WITH END WALLS - ONE ON EACH BASE RAIL. IN LOCATIONS REQUIRING TWO ANCHORS DUE TO WIND, ONE ANCHOR IS TO BE ON EACH SIDE OF THE COLUMN POST WITH A PIER.
- ANCHORS IN CLOSE PROXIMITY TO EACH OTHER MUST HAVE A MIN. 4" SPACING.
- MIN. NUMBER OF CONCRETE ANCHORS PER POST WITH A PIER SHALL BE AS SHOWN IN TABLE 11-C.2.
- TWO ANCHORS AND A PIER ARE REQUIRED AT DIAGONAL BRACING LOCATIONS WHEN REQUIRED.
- ALL POSTS NOT SUPPORTED ON CONCRETE PIERS SHALL BE ANCHORED TO THE GROUND WITH A 1/2" X 30" LG. THREADED ROD. RODS WILL HAVE A PRE-FORMED HEAD AT THE TOP AND ONE COAT OF RUST PROOF MATERIAL.
- PIERS SHALL BE FORMED BY DIGGING A HOLE OF THE SAME SIZE AS THE PIER ON LEVEL GRADE AND FILLING IT WITH CONCRETE. THRD. ROD ANCHORS SHOULD BE DROPPED INTO THE PIERS PRIOR TO POURING THE CONCRETE.
- ASSUMED SOIL BEARING CAPACITY IS TO BE A MIN. OF 1500 PSF.
- CONCRETE STRENGTH TO BE A MIN OF 2500 PSI @ 28 DAYS.

TABLE 11-C.2: ANCHOR SCHEDULE

ENCLOSURE	WIND SPEED (MPH)	ANCHOR SIZE/NUMBER
ENCLOSED	□ 105 TO 135	(1) 1/2"Ø X 7"
	□ 136 TO 180	(2) 1/2"Ø X 7"
OPEN	□ 105 TO 135	(1) 1/2"Ø X 7"
	□ 136 TO 180	(2) 1/2"Ø X 7"

NOTES:

- ANCHORS ARE TO BE CONCRETE WEDGE OR EXPANSION ANCHORS.
- MIN. EMBEDMENT DEPTH TO BE 2 7/8".
- ANCHORS TO BE SPACED NO MORE THAN 6" FROM POSTS.

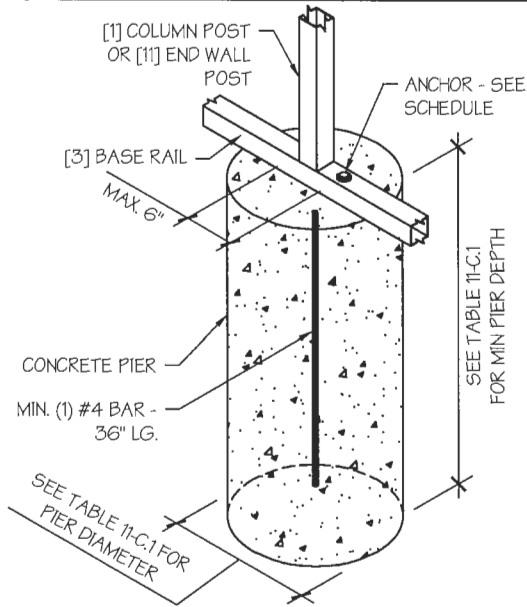

CONCRETE PIER DETAIL

SCALE: NTS

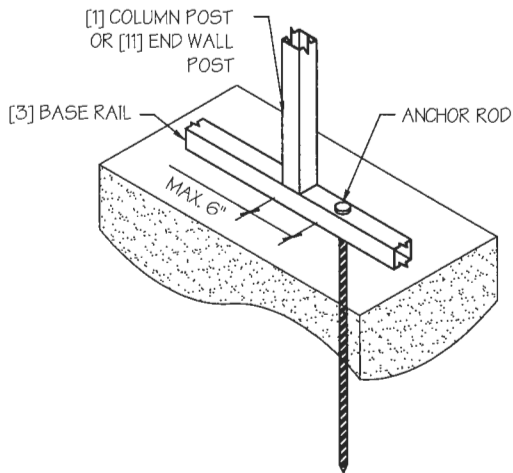

ANCHOR ROD INTO SOIL DETAIL

SCALE: NTS

TABLE 11-C.1: CONC. PIER SCHEDULE

WIND SPEED (MPH)	MIN. SIZE REQD.
□ 105 TO 130	18"Ø X 36"
□ 140 TO 155	18"Ø X 42"
□ 165 TO 180	18"Ø X 48"

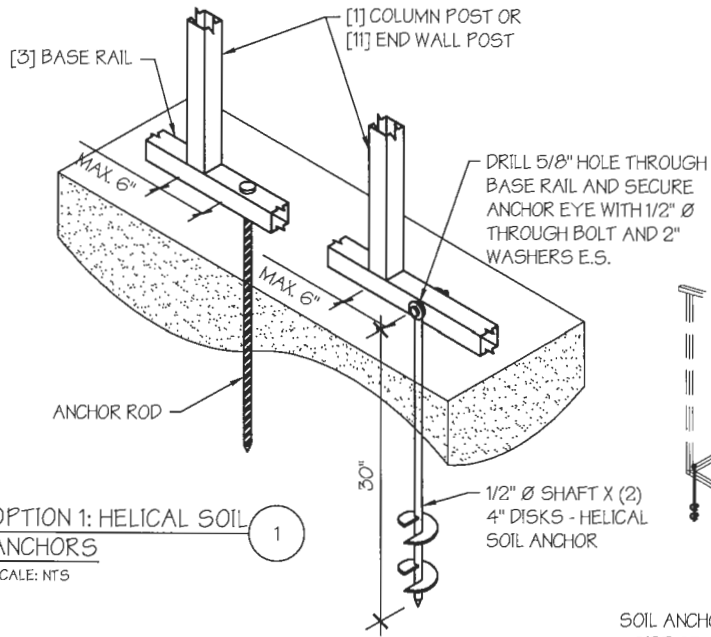

OPTION 1: HELICAL SOIL ANCHORS
SCALE: NTS

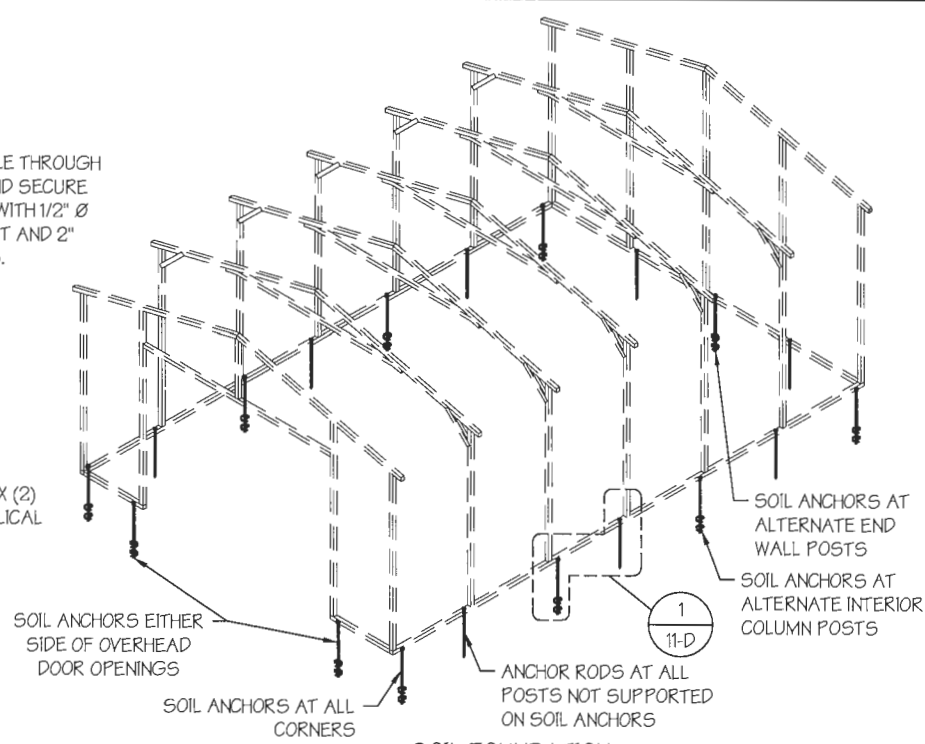

SOIL FOUNDATION
SCALE: NTS

SOIL FOUNDATION NOTES:

- DESIGNS SHOWN ON THIS SHEET ARE FOR SOIL ANCHOR FOUNDATION.
- SOIL ANCHORS (HELICAL OR ROCK/ASPHALT) SHALL BE LOCATED AT ALL 4 CORNERS, ON EACH SIDE OF OVERHEAD DOOR OPENINGS, ON POSTS WITH DIAGONAL BRACING IF REQUIRED, AND ON ALTERNATE INTERIOR COLUMN POSTS AND END WALLS POSTS.
- HELICAL ANCHORS ARE TO BE USED ONLY IF THE DRIVING TORQUE INTO THE GROUND IS 150 FT-LBS OR GREATER. MANUFACTURER IS NOT RESPONSIBLE FOR SOIL QUALITY AT SITE.
- HELICAL ANCHORS CAN ONLY BE USED FOR CLASS 2, 3 & 4 SOILS (SEE SOIL CLASSIFICATIONS THIS PAGE).
- ALL POSTS WITH NO ANCHORS ADJACENT SHALL BE ANCHORED TO THE GROUND WITH A 1/2" X 30" LG. ROD. RODS WILL HAVE A PRE-FORMED HEAD AT THE TOP AND ONE COAT OF RUST PROOF MATERIAL.
- ASSUMED SOIL BEARING CAPACITY IS TO BE A MIN. OF 1500 PSF.

SOIL CLASSIFICATIONS:

SOIL CLASS	DESCRIPTION
2	SANDY GRAVEL AND GRAVEL, VERY THIN DENSE AND/OR CEMENTED SANDS, COARSE GRAVEL/COBBLES, PRELOADED SILTS, CLAYS AND CORAL.
3	SAND, SILTY SAND, CLAYEY SAND, SILTY GRAVEL, MEDIUM DENSE COARSE SANDS, SANDY GRAVEL, VERY STIFF SILT AND SANDY CLAYS.
4	LOOSE TO MEDIUM DENSE SANDS, FIRM TO STIFF CLAYS AND SILTS AND ALLUVIAL FILLS.

*FROM HUD "MODEL MANUFACTURED HOME INSTALLATION STANDARDS"

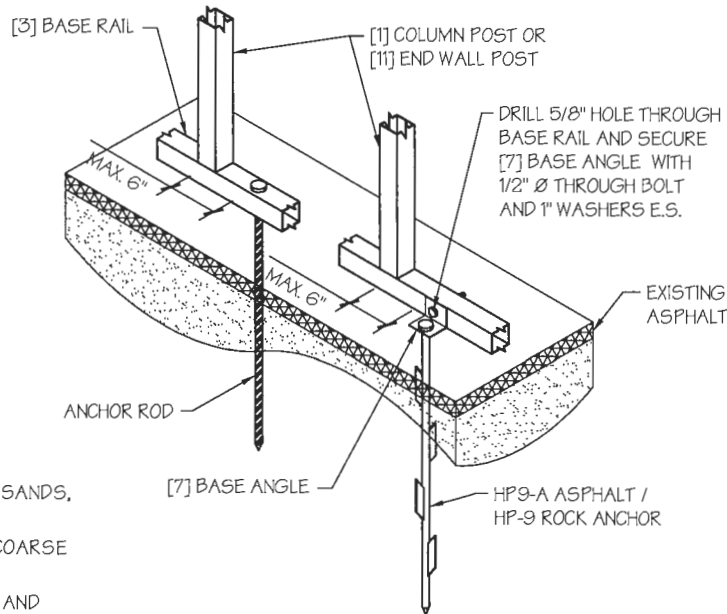

OPTION 2: ROCK / ASPHALT ANCHORS
SCALE: NTS

MANUFACTURED BY:



DRAWING INFORMATION

PROJECT: 22'-0" WIDE BUILDINGS

LOCATION: STATE OF MICHIGAN

PROJECT NO.: 451-22-1572

SHEET TITLE:

FOUNDATION OPTION 4:
SOIL ANCHORS

SHEET NO.: 11-D / 11

DRAWN BY: AW DATE: 5/17/22

CHECKED BY: OAA DATE: 5/17/22

LEGAL INFORMATION

- ANY DUPLICATION OF THIS DRAWING IN WHOLE OR PART IS STRICTLY FORBIDDEN. ANYONE DOING SO WILL BE PROSECUTED UNDER THE FULL EXTENT OF THE LAW.
- DRAWINGS VALID UP TO 1 YEAR FROM DATE OF ISSUE.

SEAL:

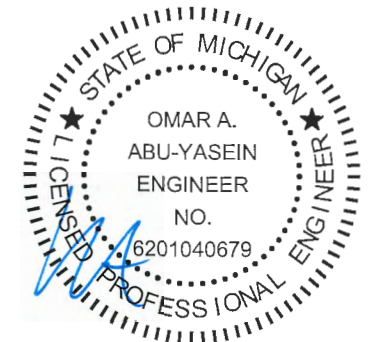

DATE EXPIRES: **03-24-2024**

DATE SIGNED: **05-20-2022**