



REGULAR / A-FRAME 12'-0" WIDE CARPORT STYLE BUILDINGS

MANUFACTURED BY:



DESIGN NOTES

1. ALL CONSTRUCTION SHALL BE PROVIDED IN ACCORDANCE WITH IBC 2018, OSHA, AISC 360, AISI 100, ASCE 7-16, AWS D1.3 CODES AND ALL APPLICABLE LOCAL REQUIREMENTS.
2. ALL MATERIALS IDENTIFIED BY MANUFACTURER NAME MAY BE SUBSTITUTED WITH MATERIAL EQUAL OR EXCEEDING ORIGINAL.
3. ALL SHOP CONNECTIONS SHALL BE WELDED CONNECTIONS.
4. ALL STRUCTURAL FIELD CONNECTIONS SHALL BE #12-14 X 3/4" SDS (ESR-2196 OR EQ) WITHOUT WASHERS.
5. STEEL SHEATHING SHALL BE 29GA. CORRUGATED GALV. OR PAINTED STEEL - MAIN RIB HT. 3/4" (FY=80KSI) OR EQ. CONNECTIONS SHALL BE #12-14 X 3/4" SDS (ESR-2196 OR EQ) WITH NEOPRENE WASHERS.
6. ALL STRUCTURAL LIGHT GAUGE TUBING AND CHANNELS SHALL BE GRADE 50 STEEL (FY = 50 KSI, FU = 65 KSI).
7. STRUCTURAL TUBE 2 1/2" X 2 1/2" - 14GA. IS EQUIVALENT TO TS 2 1/4" X 2 1/4" - 12GA AND EITHER ONE MAY BE USED IN LIEU OF THE OTHER.
8. GYPSUM BOARD OR DRYWALL FINISH OR ANY BRITTLE BASE MATERIAL IS NOT CONSIDERED OR ACCOUNTED FOR ON THE DESIGN CRITERIA.
9. ALL DESIGN CRITERIA MUST BE INCREASED TO THE NEXT HIGHER INCREMENT BASED ON THE TABLES ON PAGE 4. NO INTERPOLATION IS ALLOWED.

DESIGN CRITERIA

- | | |
|------------------|---------------------|
| PREVAILING CODE: | MBC 2015 (IBC 2015) |
| USE GROUP: | U (CARPORTS, BARNS) |
| RISK CATEGORY: | I |
-
- | | |
|-----------------------------|---|
| 1. ROOF DEAD LOAD (D) | D = 4 PSF |
| 2. ROOF LIVE/SNOW LOAD (Lr) | Lr = 20 - 61 PSF
(AS PER SNOW LOAD
SEE TABLE 4) |
| 3. SNOW LOAD (S) | |
| GROUND SNOW LOAD | P _g = 20 - 90 PSF |
| IMPORTANCE FACTOR | I _s = 0.8 |
| THERMAL FACTOR | C _t = 1.2 |
| EXPOSURE FACTOR | C _e = 1.0 |
| ROOF SLOPE FACTOR | C _s = 1.0 |
| 4. WIND LOAD (W) | |
| BASIC WIND SPEED | V _{ULT} = 105 - 180 MPH |
| EXPOSURE | C |
| 5. SEISMIC LOAD (E) | |
| DESIGN CATEGORY | D |
| IMPORTANCE FACTOR | I _e = 1.00 |

LOAD COMBINATIONS:

1. D + (Lr OR S)
2. D + (0.6W OR ±0.7E)
3. D + 0.75 (0.6W OR ±0.7E) + 0.75 (Lr OR S)
4. 0.6D + (0.6W OR ±0.7E)

DRAWING INDEX

COVER SHEET	----	1
SCHEDULES & MEMBER SECTIONS	----	2
FRAME SECTIONS & DETAILS	----	3
SPACING SCHEDULES & ENCLOSURE NOTES	----	4
PURLIN & GIRT SCHEDULES	----	5
SHEATHING OPTIONS	----	6
SIDE WALL FRAMING & OPENINGS	----	7
END WALL FRAMING & OPENINGS	----	8-A, 8-B
CORNER BRACING DETAILS	----	9
OPTIONAL LEAN-TO ADDITION	----	10
FOUNDATION OPTIONS	----	11-A TO 11-D

DRAWING INFORMATION

PROJECT: 12'-0" WIDE BUILDINGS

LOCATION: STATE OF MICHIGAN

PROJECT NO.: 451-22-1572

SHEET TITLE:

COVER SHEET

SHEET NO.: 1 / 11

DRAWN BY: AW DATE: 5/17/22

CHECKED BY: OAA DATE: 5/17/22

LEGAL INFORMATION

- ANY DUPLICATION OF THIS DRAWING IN WHOLE OR PART IS STRICTLY FORBIDDEN. ANYONE DOING SO WILL BE PROSECUTED UNDER THE FULL EXTENT OF THE LAW. - DRAWINGS VALID UP TO 1 YEAR FROM DATE OF ISSUE.

SEAL:

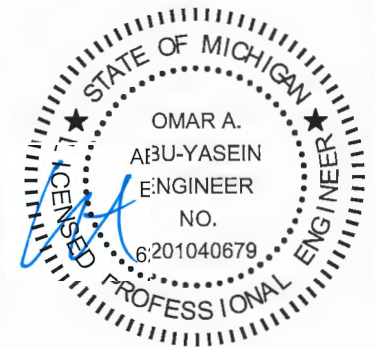

DATE EXPIRES: 03-24-2024

DATE SIGNED: 05-20-2022

CUSTOMER INFORMATION

OWNER:
ADDRESS:

DESIGN LOADS

GROUND SNOW:

ROOF LIVE LOAD:

BASIC WIND SPEED:

BUILDING INFORMATION

WIDTH:

LENGTH:

HEIGHT:

- FRAME TYPE:
- A-FRAME
 REGULAR
- FULL
 PARTIAL
 OPEN
- ENCLOSURE TYPE:

CERTIFICATION VALIDITY NOTICE

DATE OF PLANS EXPIRATION: 05-20-2023

CERTIFICATION ON THESE DRAWINGS IS VALID FOR ONE YEAR FROM DATE OF ISSUE

TABLE 2.1: MEMBER PROPERTIES

NO.	LABEL	PROPERTY	DETAIL NO.
1	COLUMN POST	2.5" X 2.5" X 14GA TUBE	1
2	ROOF BEAM	2.5" X 2.5" X 14GA TUBE	1
3	BASE RAIL	2.5" X 2.5" X 14GA TUBE	1
4	PEAK BRACE	2.5" X 2.5" 14GA CHANNEL	4
5	KNEE BRACES	2.5" X 1.5" 14GA CHANNEL	4
6	CONNECTOR SLEEVE	2.25" X 2.25" X 12GA TUBE	2
7	BASE ANGLE	2" X 2" X 3" LG. 3/16" ANGLE	10
8	PURLIN	4.25" X 1.5" X 14GA / 18GA HAT CHANNEL	5
9	GIRT	4.25" X 1.5" X 14GA / 18GA HAT CHANNEL	5
9A	OPT. END WALL GIRT	2.5" X 1.5" 14GA CHANNEL	1
10	SHEATHING	29 GA CORRUGATED SHEET	8
11	END WALL POST	2.5" X 2.5" X 14GA TUBE	1
12	DOOR POST	2.5" X 2.5" X 14GA TUBE	1
13	SINGLE HEADER	2.5" X 2.5" X 14GA TUBE	1
14	DOUBLE HEADER	DBL. 2.5" X 2.5" X 14GA TUBE	1
15	SERVICE DOOR / WINDOW FRAMING	2.5" X 2.5" X 14GA TUBE	1
16	ANGLE BRACKET	2" X 2" X 2" LG. 14GA ANGLE	7
17	STRAIGHT BRACKET	2" X 2" X 4" LG. 14GA PLATE	6
18	PB SUPPORT	2.5" X 2.5" X 14GA TUBE	1
19	DIAGONAL BRACE	2" X 2" X 14 GA TUBE	3
20	GABLE BRACE	2" X 2" X 14 GA TUBE	3
21	DB BRACKET	2.25" X 2.25" X 6" LG. 14GA ANGLE	9
22	TRUSS SPACER	2.5" X 2.5" X 14GA TUBE	1
23	ALL FASTENERS	#12 X 1" SELF-DRILL SCREWS (ESR-2196 OR EQ) W/ NEOPRENE/STEEL WASHER	

TABLE 2.2: SHEATHING FASTENER SCHEDULE

LOCATION	CORNER PANELS	SIDE LAPS	EDGE LAPS	ELSEWHERE
SPACING	9" C/C	MIN. 1	4 1/2" C/C	9" C/C

FASTENER TYPE: #12X1" SELF-DRILL SCREWS (ESR-2196 OR EQ) W/ NEOPRENE/STEEL WASHER
 *SEE TYP. SHEATHING FASTENER SCHEDULE DIAGRAM ON PAGE 6.

TABLE 2.3: GAUGE THICKNESS

GAUGE	29	18	14	12
THICKNESS (IN)	0.0135	0.049	0.083	0.109

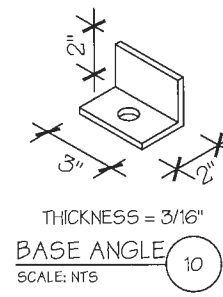
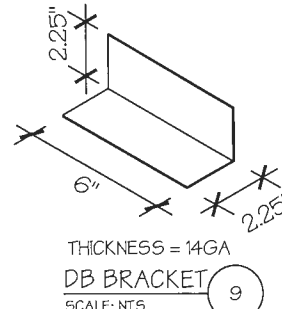
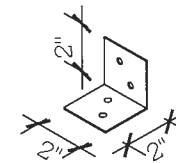
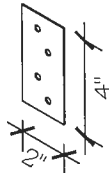
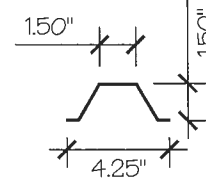
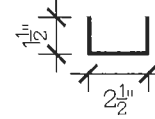
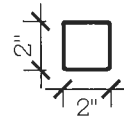
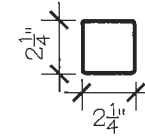
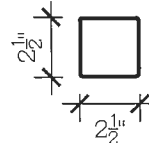
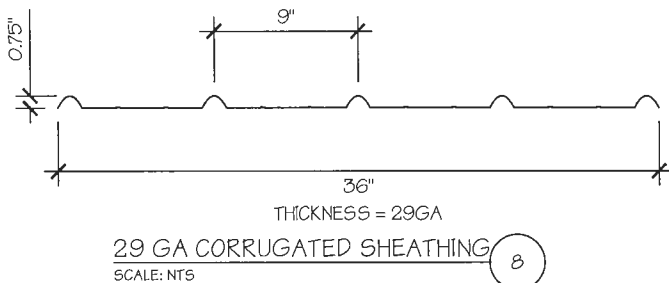

MANUFACTURED BY:



DRAWING INFORMATION

PROJECT: 12'-0" WIDE BUILDINGS
 LOCATION: STATE OF MICHIGAN
 PROJECT NO.: 451-22-1572
 SHEET TITLE:

SCHEDULES & MEMBER SECTIONS

SHEET NO.: 2 / 11
 DRAWN BY: AW DATE: 5/17/22
 CHECKED BY: OAA DATE: 5/17/22

LEGAL INFORMATION

- ANY DUPLICATION OF THIS DRAWING IN WHOLE OR PART IS STRICTLY FORBIDDEN. ANYONE DOING SO WILL BE PROSECUTED UNDER THE FULL EXTENT OF THE LAW.
 - DRAWINGS VALID UP TO 1 YEAR FROM DATE OF ISSUE.

SEAL:

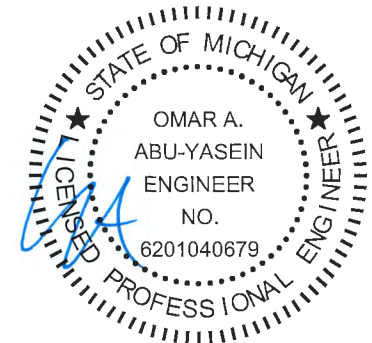

DATE EXPIRES: 03-24-2024
 DATE SIGNED: 05-20-2022

MANUFACTURED BY:



DRAWING INFORMATION

PROJECT: 12'-0" WIDE BUILDINGS

LOCATION: STATE OF MICHIGAN

PROJECT NO.: 451-22-1572

SHEET TITLE:

FRAME SECTIONS & DETAILS

SHEET NO.: 3 / 11

DRAWN BY: AW DATE: 5/17/22

CHECKED BY: OAA DATE: 5/17/22

LEGAL INFORMATION

- ANY DUPLICATION OF THIS DRAWING IN WHOLE OR PART IS STRICTLY FORBIDDEN. ANYONE DOING SO WILL BE PROSECUTED UNDER THE FULL EXTENT OF THE LAW. - DRAWINGS VALID UP TO 1 YEAR FROM DATE OF ISSUE.

SEAL:

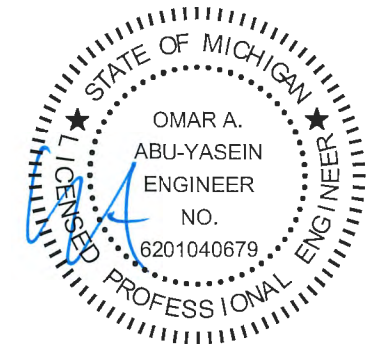

DATE EXPIRES: **03-24-2024**

DATE SIGNED: **05-20-2022**

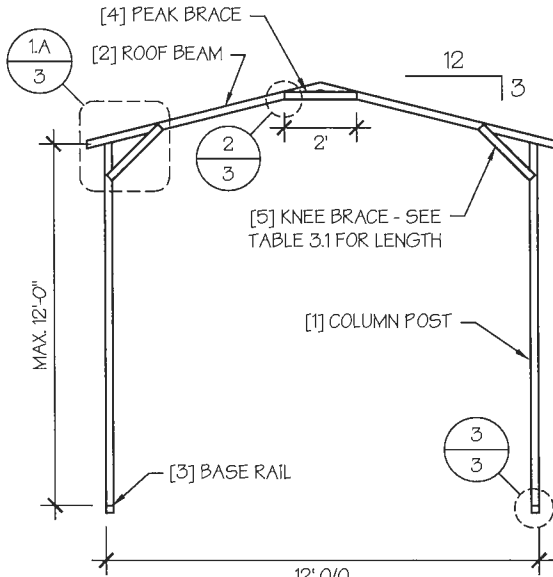

TYP. A-FRAME SECTION

SCALE: NTS

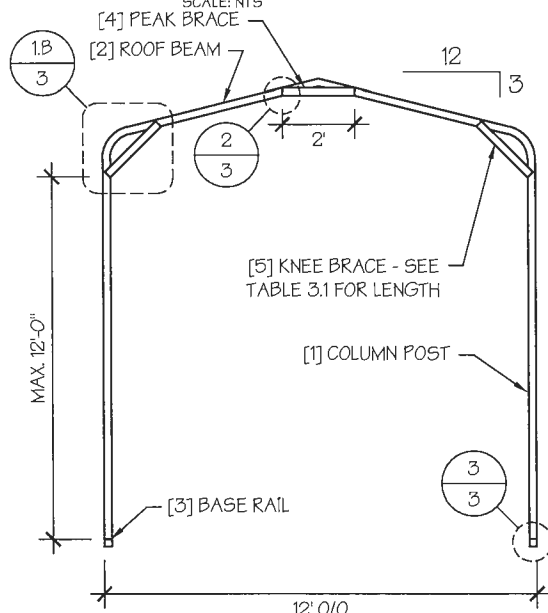

TYP. REGULAR FRAME SECTION

SCALE: NTS

TABLE 3.1: KNEE BRACE SCHEDULE

EAVE HEIGHT	KNEE BRACE LENGTH
<input type="checkbox"/> UP TO 8'	24"
<input type="checkbox"/> 9' TO 12'	36"

TABLE 3.2 FASTENER SCHEDULE

WIND SPEED (MPH)	NO. OF FASTENERS
<input type="checkbox"/> 105 TO 125	4
<input type="checkbox"/> 130 TO 155	6
<input type="checkbox"/> 160 TO 180	8

NOTE: COLUMN POST MAY BE ADJUSTED ±1" FOR LEVELING. MANUFACTURER IS NOT RESPONSIBLE FOR LEVELING OF GROUND AND/OR CONCRETE SURFACE PROVIDED BY OTHERS.

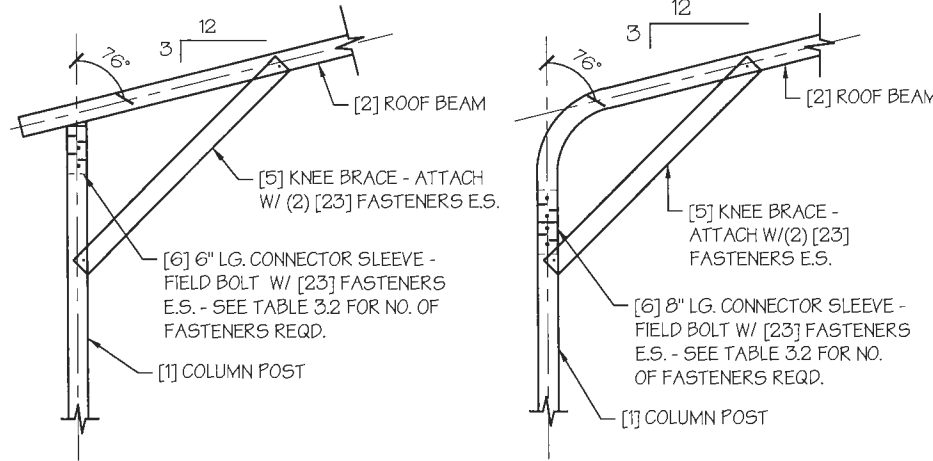

A. 'A'-FRAME

B. REGULAR FRAME

EAVE DETAIL

SCALE: NTS

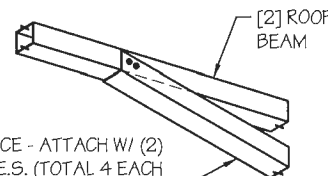

PEAK BRACE CONNECTION DETAILS

SCALE: NTS

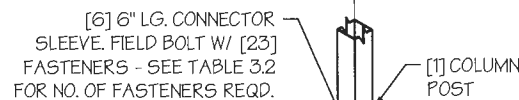

BASE DETAIL

SCALE: NTS

1/2" RET. TYP.

TABLE 4: FRAME SPACING CHART / SCHEDULE

GROUND SNOW / ROOF LIVE LOAD (PSF)	■ ENCLOSED BUILDINGS							■ OPEN BUILDINGS						
	WIND SPEED (MPH)							WIND SPEED (MPH)						
	□105	□115	□130	□140	□155	□165	□180	□105	□115	□130	□140	□155	□165	□180
□ 30 / 20	60	60	54/60	54	42	42	36	60	54/60	48/60	42/54	36/42	36/42	36
□ 40 / 27	48/60	48/60	42/60	42/54	42	42	36	48/60	48/60	42/60	42/54	36/42	36/42	36
□ 50 / 34	40/54	40/54	40/54	40/54	40/42	40/42	36	40/54	40/54	40/54	40/54	36/42	36/42	36
□ 60 / 41	36/48	36/48	36/48	36/48	36/42	36/42	36	36/48	36/48	36/48	36/48	36/42	36/42	36
□ 70 / 47	32/42	32/42	32/42	32/42	32/42	32/42	32/36	32/42	32/42	32/42	32/42	32/42	32/42	32/36
□ 80 / 54	30/42	30/42	30/42	30/42	30/36	30/36	30/36	30/42	30/42	30/42	30/42	30/36	30/36	30/36
□ 90 / 61	30/36	30/36	30/36	30/36	30/36	30	30	30/36	30/36	30/36	30/36	30	30	30
■ 30 / 20	60	60	54/60	54	48	42/48	42	60	54/60	48/60	42/54	36/48	36/48	36/42
■ 40 / 27	48/60	48/60	42/60	42/54	42/48	42/48	42	48/60	48/60	42/60	42/54	36/48	36/48	36/42
■ 50 / 34	40/54	40/54	40/54	40/54	40/48	40/48	40/42	40/54	40/54	40/54	40/54	36/48	36/48	36/42
■ 60 / 41	36/48	36/48	36/48	36/48	36/48	36/48	36/42	36/48	36/48	36/48	36/48	36/48	36/48	36/42
■ 70 / 47	32/42	32/42	32/42	32/42	32/42	32/42	32/42	32/42	32/42	32/42	32/42	32/42	32/42	32/42
■ 80 / 54	30/42	30/42	30/42	30/42	30/36	30/36	30/36	30/42	30/42	30/42	30/42	30/36	30/36	30/36
■ 90 / 61	30/36	30/36	30/36	30/36	30/36	30/36	30/36	30/36	30/36	30/36	30/36	30/36	30/36	30/36
■ 30 / 20	60	60	54/60	54	48	42/48	42	60	54/60	48/60	42/54	36/48	36/48	36/42
■ 40 / 27	48/60	48/60	42/60	42/54	42/48	42/48	42	48/60	48/60	42/60	42/54	36/48	36/48	36/42
■ 50 / 34	40/54	40/54	40/54	40/54	40/48	40/48	40/42	40/54	40/54	40/54	40/54	36/48	36/48	36/42
■ 60 / 41	36/48	36/48	36/48	36/48	36/48	36/48	36/42	36/48	36/48	36/48	36/48	36/48	36/48	36/42
■ 70 / 47	32/42	32/42	32/42	32/42	32/42	32/42	32/42	32/42	32/42	32/42	32/42	32/42	32/42	32/42
■ 80 / 54	30/42	30/42	30/42	30/42	30/36	30/36	30/36	30/42	30/42	30/42	30/42	30/36	30/36	30/36
■ 90 / 61	30/36	30/36	30/36	30/36	30/36	30/36	30/36	30/36	30/36	30/36	30/36	30/36	30/36	30/36

EAVE HEIGHT = 10'-0" TO 12'-0"

EAVE HEIGHT = 7'-0" TO 9'-0"

EAVE HEIGHT = UP TO 6'-0"

NOTES:

1. FRAME SPACINGS ARE IN UNITS OF INCHES (IN).
2. WHERE TWO VALUES ARE SHOWN, THE HIGHER VALUE CAN ONLY BE USED FOR VERTICAL SHEATHING.
3. SNOW LOADS AND ROOF LIVE LOADS ARE IN POUNDS PER SQUARE FOOT (PSF). WIND SPEED IS 3 SEC. GUST IN MILES PER HOUR (MPH).
4. FOR VALUES THAT LIE BETWEEN TWO CELLS, THE HIGHER (MORE STRINGENT) VALUE HAS TO BE USED. INTERPOLATION BETWEEN CELLS IS NOT ALLOWED.

ENCLOSURE CLASSIFICATION:

1. **ENCLOSED BUILDING** = ALL 4 WALLS FULLY ENCLOSED WITH DOORS/WINDOWS = USE ENCLOSED BUILDING SPACING CHART.
2. **OPEN BUILDING** = ALL 4 WALLS FULLY OPEN = USE OPEN BUILDING SPACING CHART.
3. **3FT PARTIALLY ENCLOSED** = BOTH END-WALLS FULLY OPEN, WITH BOTH SIDE-WALLS ONLY 3FT ENCLOSED = USE OPEN BUILDING SPACING CHART.
4. **PARTIALLY ENCLOSED** = BOTH END-WALLS FULLY OPEN, WITH BOTH SIDE-WALLS ENCLOSED MORE THAN 3FT = START WITH OPEN BUILDING SPACING CHART AND THEN REDUCE SPACING BY 6".
5. **3 SIDED ENCLOSED** = ALL WALLS ARE ENCLOSED EXCEPT FOR 1 END-WALL = START WITH ENCLOSED BUILDING SPACING + THE OPEN END FRAME MUST HAVE EITHER A GABLED END OR HAVE DOUBLED WELDED LEGS.
6. FOR ALL SHEATHING ENCLOSURES NOT LISTED ABOVE, REFER TO SHEET 5 FOR SPACING AND DESIGN REQUIREMENTS.

GENERAL NOTES:

1. THE MAX. BUILDING LENGTH FOR ENCLOSED BUILDINGS IS 50'-0". THIS CAN BE INCREASED BY ADDING A DOUBLE FRAME AT THE CENTER TO BREAK THE LENGTH OF THE BUILDING.
2. BUILDINGS WITH PARTIALLY ENCLOSED END WALLS NEED TO HAVE SIDE WALL BRACING TO SUPPORT THE PARTIALLY ENCLOSED END WALL. (SEE FIGURE A ON SHEET 5).

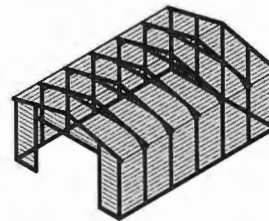

TYP. ENCLOSED BUILDING
SCALE: NTS

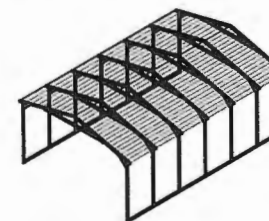

TYP. OPEN BUILDING
SCALE: NTS

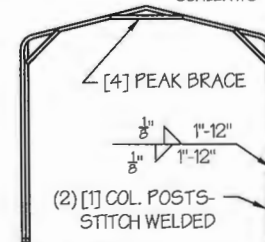

TYP. OPEN END WALL ON 3
SIDE ENCLOSED BUILDING
SCALE: NTS

MANUFACTURED BY:



DRAWING INFORMATION

PROJECT: 12'-0" WIDE BUILDINGS

LOCATION: STATE OF MICHIGAN

PROJECT NO.: 451-22-1572

SHEET TITLE:

SPACING SCHEDULES
& ENCLOSURE NOTES

SHEET NO.: 4 / 11

DRAWN BY: AW DATE: 5/17/22

CHECKED BY: OAA DATE: 5/17/22

LEGAL INFORMATION

- ANY DUPLICATION OF THIS DRAWING IN WHOLE OR PART IS STRICTLY FORBIDDEN. ANYONE DOING SO WILL BE PROSECUTED UNDER THE FULL EXTENT OF THE LAW. - DRAWINGS VALID UP TO 1 YEAR FROM DATE OF ISSUE.

SEAL:

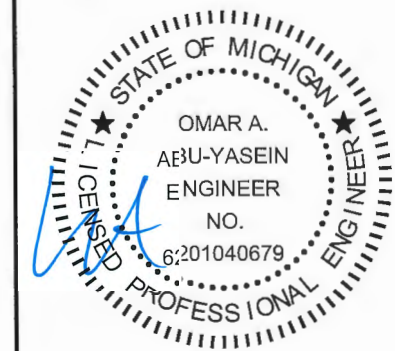

DATE EXPIRES: 03-24-2024

DATE SIGNED: 05-20-2022

TABLE 5.1: PURLIN SPACING SCHEDULE

GROUND SNOW / ROOF LIVE LOAD (PSF)	14GA. HAT CHANNEL PURLIN							18GA. HAT CHANNEL PURLIN						
	WIND SPEED (MPH)							WIND SPEED (MPH)						
	105	115	130	140	155	165	180	105	115	130	140	155	165	180
30/20	54	48	42	36	30	24	24	36	30	24	18	18	12	12
40/27	42	42	42	36	30	24	24	30	30	24	18	18	12	12
50/34	40	40	40	36	30	24	24	24	24	24	18	18	12	12
60/41	36	36	36	36	30	24	24	18	18	18	18	18	12	12
70/47	32	32	32	32	30	24	24	18	18	18	18	18	12	12
80/54	30	30	30	30	30	24	24	18	18	18	18	18	12	12
90/61	24	24	24	24	24	24	24	12	12	12	12	12	12	12
30/20	54	48	42	42	36	30	30	48	36	30	24	18	18	12
40/27	42	42	42	42	36	30	30	42	36	30	24	18	18	12
50/34	40	40	40	40	36	30	30	30	30	30	24	18	18	12
60/41	36	36	36	36	36	30	30	30	30	30	24	18	18	12
70/47	32	32	32	32	32	30	30	24	24	24	24	18	18	12
80/54	32	32	32	32	32	30	30	18	18	18	18	18	18	12
90/61	30	30	30	30	30	30	30	18	18	18	18	18	18	12
30/20	54	48	42	42	36	36	30	54	48	36	30	24	24	18
40/27	42	42	42	42	36	36	30	42	42	36	30	24	24	18
50/34	40	40	40	40	36	36	30	40	40	36	30	24	24	18
60/41	36	36	36	36	36	36	30	36	36	36	30	24	24	18
70/47	32	32	32	32	32	32	30	30	30	30	30	24	24	18
80/54	32	32	32	32	32	32	30	24	24	24	24	24	24	18
90/61	30	30	30	30	30	30	30	24	24	24	24	24	24	18
30/20	54	48	42	42	36	36	30	54	48	42	42	36	30	30
40/27	42	42	42	42	36	36	30	42	42	42	42	36	30	30
50/34	40	40	40	40	36	36	30	40	40	40	40	36	30	30
60/41	36	36	36	36	36	36	30	36	36	36	36	36	30	30
70/47	32	32	32	32	32	32	30	32	32	32	32	32	30	30
80/54	32	32	32	32	32	32	30	32	32	32	32	32	30	30
90/61	30	30	30	30	30	30	30	30	30	30	30	30	30	30

NOTES:

- PURLIN SPACING UNITS ARE IN INCHES.
- FRAME SPACING NEEDS TO BE DETERMINED FROM TABLE 4.

IRREGULAR BUILDING NOTES:

- FIGURES A, B, C & D ON THE RIGHT INDICATE EXAMPLES OF IRREGULAR BUILDINGS.
- FOR IRREGULAR BUILDINGS, FRAME SPACING MUST BE REDUCED BY 12" FROM OPEN BUILDING SPACING TABLE. SEE SHEET 4 FOR OPEN BUILDING TABLE.
- SITE SPECIFICS MAY ALLOW FOR ALTERNATIVE SPACING.

TABLE 5.2: GIRT SPACING SCHEDULE

FRAME SPACING	WIND SPEED (MPH)						
	105	115	130	140	155	165	180
5'-0"	60	48	36	30	24	24	18
4'-6"	60	60	48	42	36	30	24
4'-0"	60	60	54	54	42	36	30
3'-6"	60	60	54	54	48	42	42
2'-0" TO 3'-0"	60	60	54	54	48	42	42

NOTES:

- GIRT SPACING UNITS ARE IN INCHES.
- THIS SCHEDULE IS TO BE USED FOR BOTH 14GA AND 18 GA GIRTS.
- FRAME SPACING NEEDS TO BE DETERMINED FROM TABLE 4.

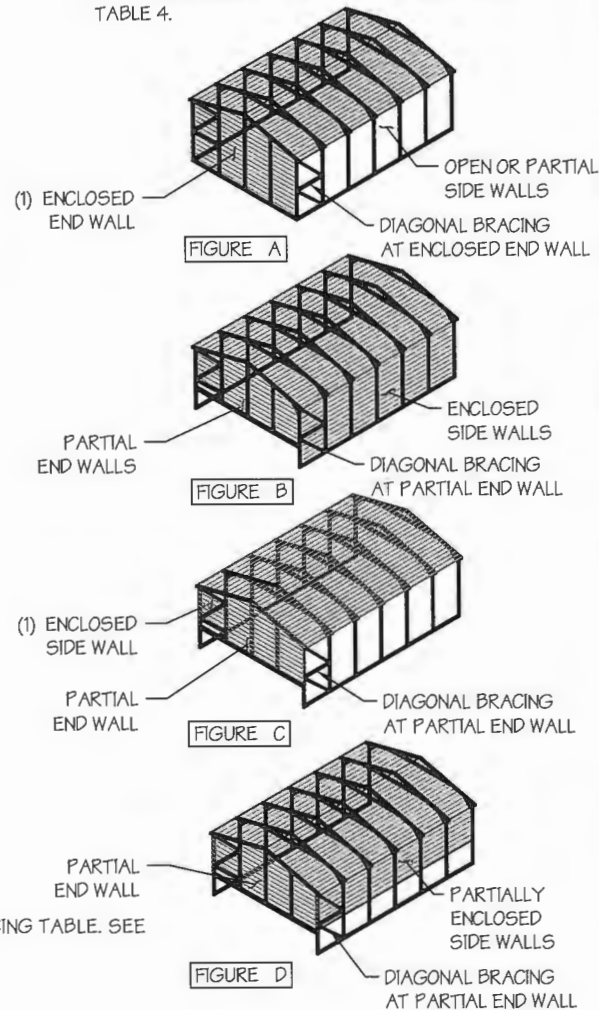

MANUFACTURED BY:



DRAWING INFORMATION

PROJECT: 12'-0" WIDE BUILDINGS
 LOCATION: STATE OF MICHIGAN
 PROJECT NO.: 451-22-1572
 SHEET TITLE:

PURLIN & GIRT SPACING SCHEDULES

SHEET NO.: 5 / 11
 DRAWN BY: AW DATE: 5/17/22
 CHECKED BY: OAA DATE: 5/17/22

LEGAL INFORMATION

- ANY DUPLICATION OF THIS DRAWING IN WHOLE OR PART IS STRICTLY FORBIDDEN. ANYONE DOING SO WILL BE PROSECUTED UNDER THE FULL EXTENT OF THE LAW.
 - DRAWINGS VALID UP TO 1 YEAR FROM DATE OF ISSUE.

SEAL:

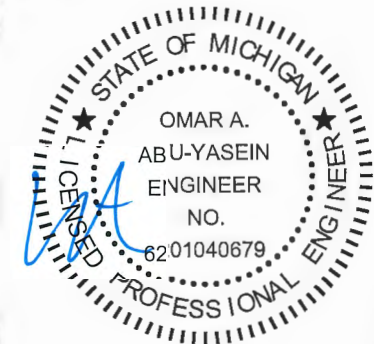

DATE EXPIRES: 03-24-2024
 DATE SIGNED: 05-20-2022

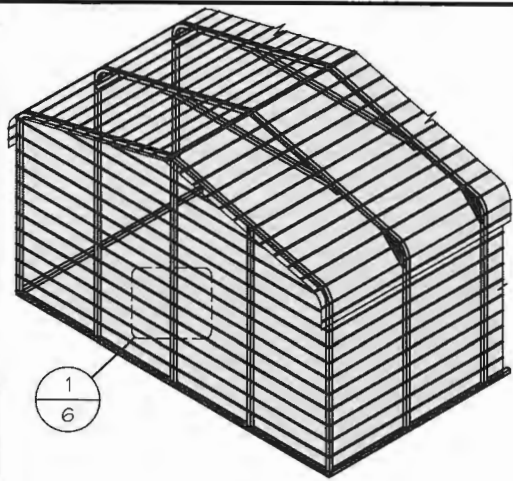

TYP. HORIZONTAL SHEATHING
SCALE: NTS

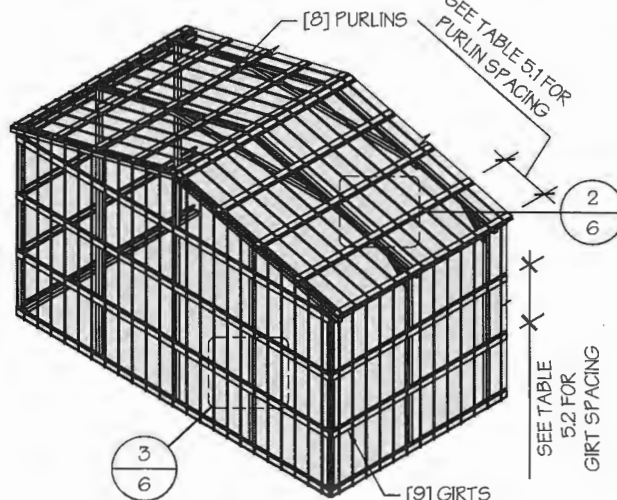

TYP. VERTICAL SHEATHING
SCALE: NTS

GENERAL SHEATHING NOTES:

1. REGULAR STYLE BUILDINGS CAN ONLY HAVE HORIZONTAL SHEATHING ON ROOF AND WALLS.
2. A-FRAME STYLE BUILDINGS CAN HAVE ANY COMBINATION OF HORIZONTAL OR VERTICAL SHEATHING ON ROOFS AND WALLS.
3. BOTH HORIZONTAL AND VERTICALS ROOF SHEATHING CAN HAVE MAX. 6" OVERHANG.
4. USING VERTICAL SHEATHING MAY ALLOW FOR GREATER FRAME SPACING. SEE NOTE 2 UNDER TABLE 4.
5. VERTICAL SHEATHING RECOMMENDED FOR BUILDINGS 30' OR LONGER

MANUFACTURED BY:



DRAWING INFORMATION

PROJECT: 12'-0" WIDE BUILDINGS

LOCATION: STATE OF MICHIGAN

PROJECT NO.: 451-22-1572

SHEET TITLE:

SHEATHING OPTIONS & DETAILS

SHEET NO.: 6 / 11

DRAWN BY: AW DATE: 5/17/22

CHECKED BY: OAA DATE: 5/17/22

LEGAL INFORMATION

- ANY DUPLICATION OF THIS DRAWING IN WHOLE OR PART IS STRICTLY FORBIDDEN. ANYONE DOING SO WILL BE PROSECUTED UNDER THE FULL EXTENT OF THE LAW.
- DRAWINGS VALID UP TO 1 YEAR FROM DATE OF ISSUE.

SEAL:

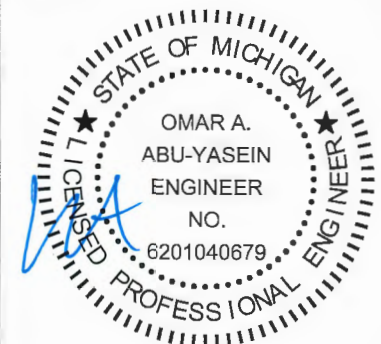

DATE EXPIRES: **03-24-2024**

DATE SIGNED: **05-20-2022**

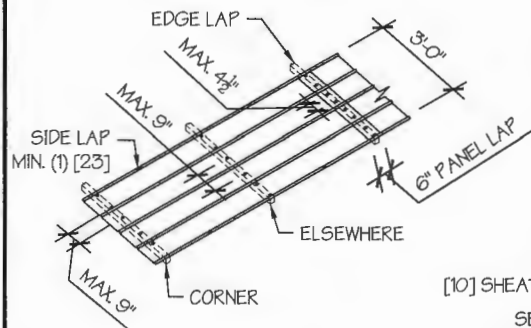

TYP. SHEATHING FASTENER SCHEDULE
SCALE: NTS

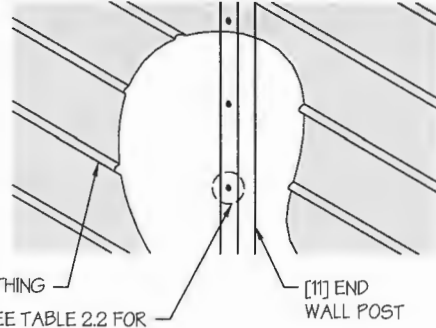

TYP. HORIZONTAL SHEATHING DETAIL 1
SCALE: NTS

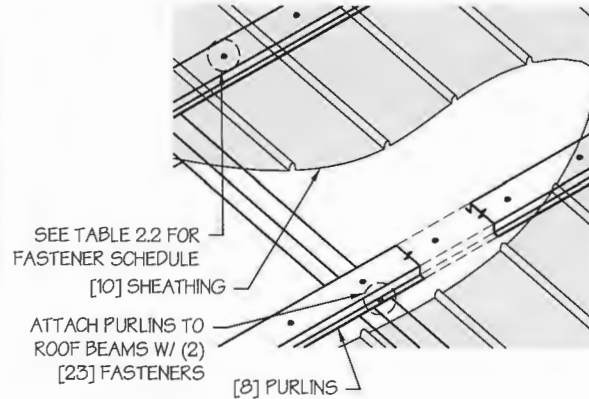

ROOF VERTICAL SHEATHING DETAIL 2
SCALE: NTS

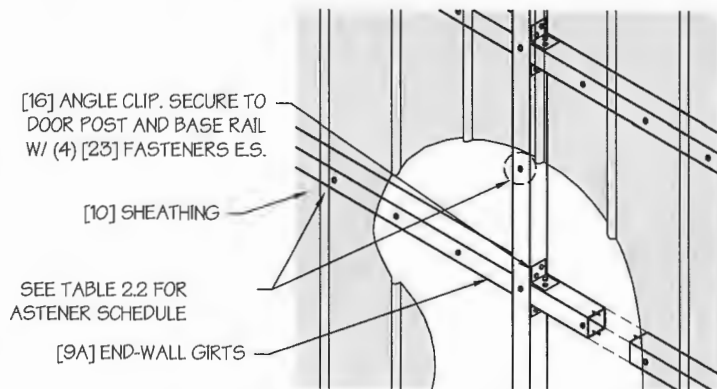

WALL VERTICAL SHEATHING - TUBE DETAIL 3
SCALE: NTS

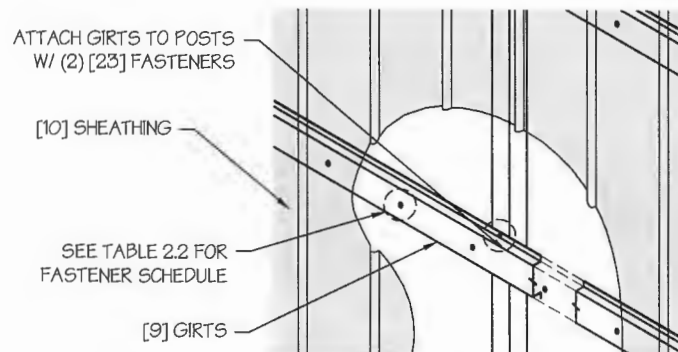

WALL VERTICAL SHEATHING - HAT CHANNEL DETAIL 3
SCALE: NTS

MANUFACTURED BY:

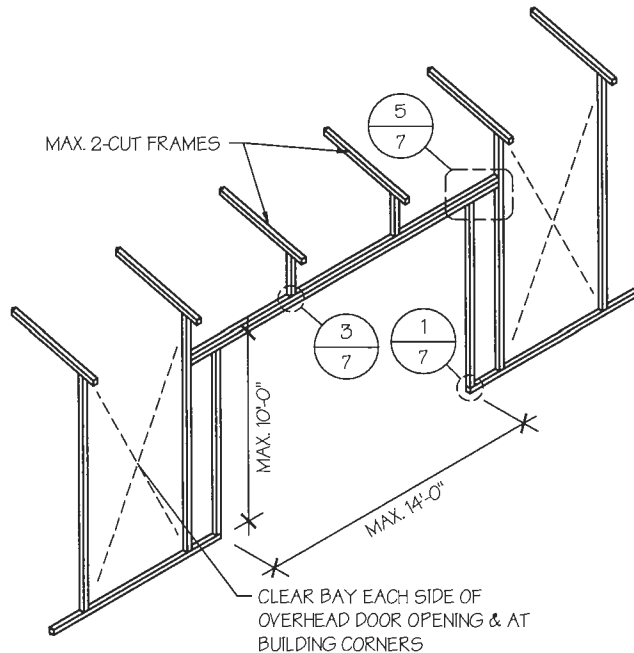

SIDE WALL OVERHEAD DOOR OPENINGS
SCALE: NTS

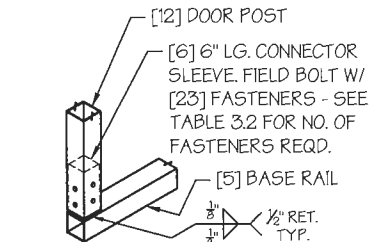

DOOR POST BOT. CONN. DETAIL 1
SCALE: NTS

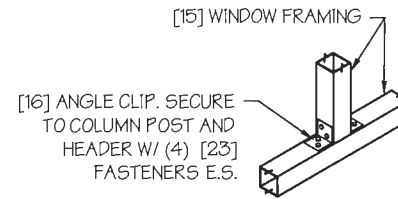

TYP. WINDOW FRAMING CONN. DETAIL 2
SCALE: NTS

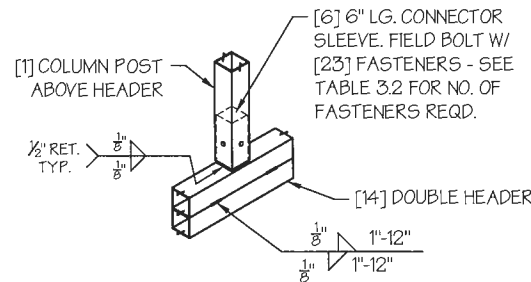

COLUMN POST ABOVE DOOR HEADER CONN. DETAIL 3
SCALE: NTS

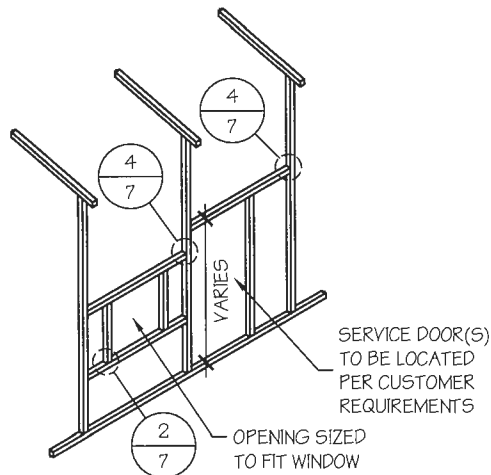

SIDE WALL SERVICE DOOR / WINDOW OPENINGS
SCALE: NTS

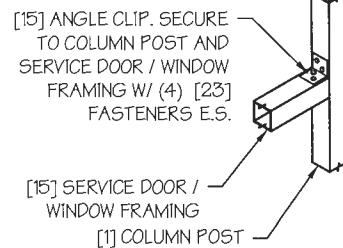

TYP. SERVICE DOOR / WINDOW FRAMING CONN. DETAIL 4
SCALE: NTS

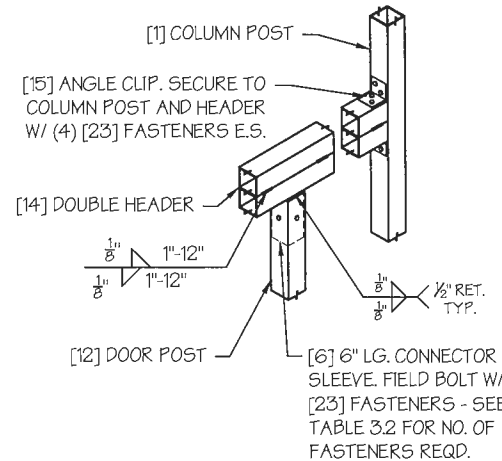

COLUMN POST ABOVE DOOR HEADER CONN. DETAIL 5
SCALE: NTS

SIDE WALL FRAMING NOTES:

- DESIGNS AND DETAILS SHOWN HERE ARE APPLICABLE TO BOTH REGULAR AND A-FRAME STYLE BUILDINGS.
- MAX. HEIGHT OF SIDE WALL OVERHEAD DOOR OPENINGS IS 2 FT LESS THAN THE EAVE HEIGHT.
- OVERHEAD DOOR OPENINGS CANNOT CUT THROUGH MORE THAN 2 FULL FRAMES.
- MIN. 1 CLEAR BAY MUST BE MAINTAINED BETWEEN ANY 2 OVERHEAD DOOR OPENINGS. A CLEAR BAY IS A SPACE BETWEEN TWO FRAMES THAT HAS NO OVERHEAD DOOR OPENINGS.
- MIN. 1 CLEAR BAY MUST ALSO BE MAINTAINED FROM THE BUILDING CORNERS.
- SERVICE DOORS AND WINDOWS CAN BE PLACED IN CLEAR BAYS OR ANY WHERE ELSE AS NEEDED.

DRAWING INFORMATION

PROJECT: 12'-0" WIDE BUILDINGS

LOCATION: STATE OF MICHIGAN

PROJECT NO.: 451-22-1572

SHEET TITLE:

SIDE WALL FRAMING & OPENINGS

SHEET NO.: 7 / 11

DRAWN BY: AW DATE: 5/17/22

CHECKED BY: OAA DATE: 5/17/22

LEGAL INFORMATION

- ANY DUPLICATION OF THIS DRAWING IN WHOLE OR PART IS STRICTLY FORBIDDEN. ANYONE DOING SO WILL BE PROSECUTED UNDER THE FULL EXTENT OF THE LAW.
- DRAWINGS VALID UP TO 1 YEAR FROM DATE OF ISSUE.

SEAL:

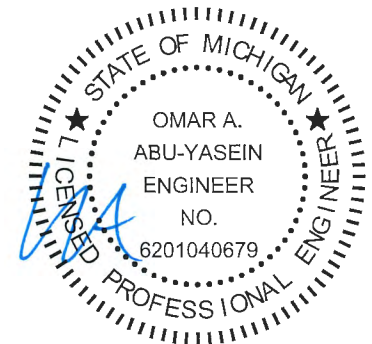

DATE EXPIRES: 03-24-2024

DATE SIGNED: 05-20-2022

SEE TABLE 8-A.1 FOR MAX. END WALL POST SPACING

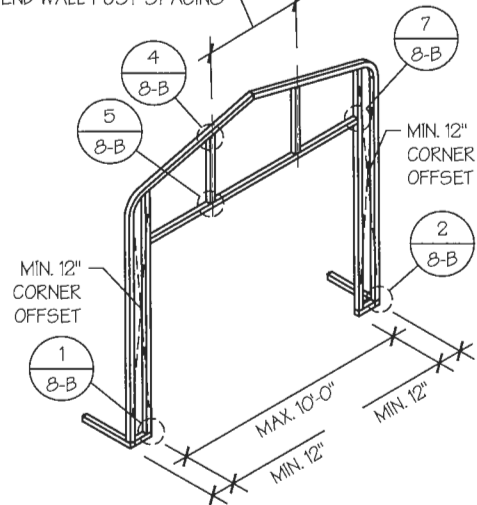

END WALL OVER HEAD DOOR OPENINGS
SCALE: NTS

SEE TABLE 8-A.1 FOR MAX. END WALL POST SPACING

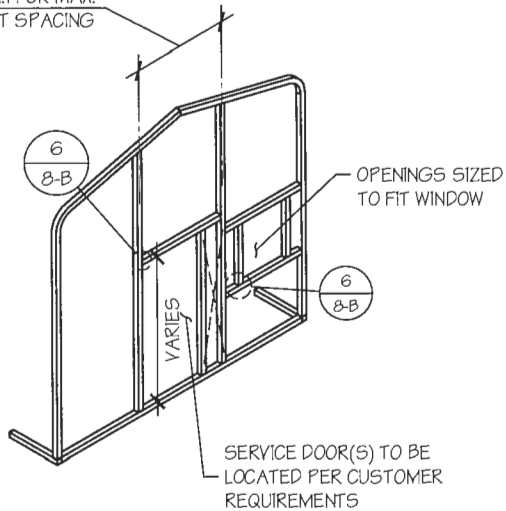

END WALL SERVICE DOOR AND WINDOW OPENINGS
SCALE: NTS

END WALL FRAMING NOTES:

- DESIGNS AND DETAILS SHOWN HERE ARE APPLICABLE TO BOTH REGULAR AND A-FRAME STYLE BUILDINGS.
- MIN. 12" CLEARANCE MUST BE MAINTAINED BETWEEN ANY TWO OPENINGS (OVERHEAD DOOR OR SERVICE DOOR) AND FROM CORNERS.
- SERVICE DOORS AND WINDOWS CAN BE PLACED AS NEEDED.
- DIAGONAL BRACES NEED TO BE ADDED FOR PARTIAL END WALL ENCLOSURES. SEE SHEET 9 FOR DIAGONAL BRACE CONNECTION DETAILS.

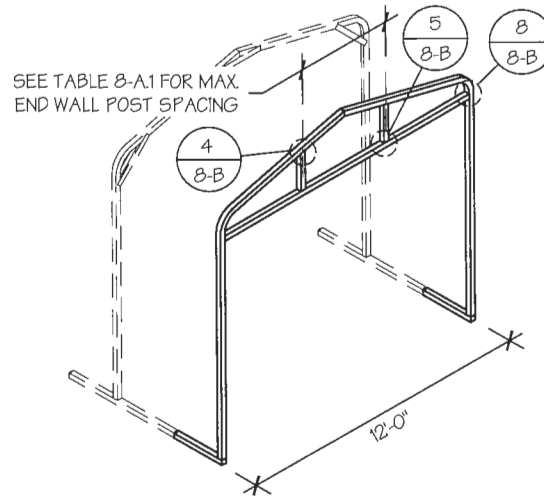

END WALL GABLES
SCALE: NTS

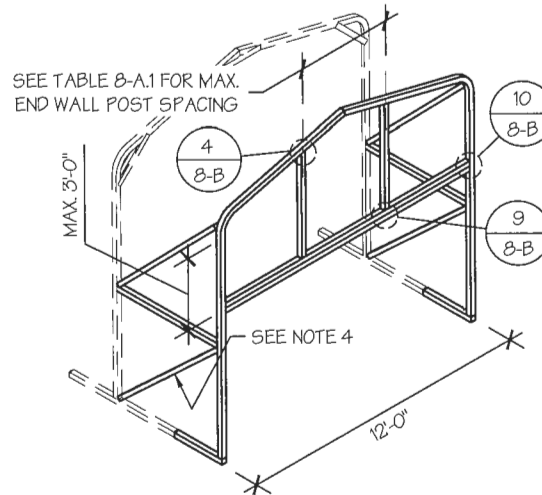

PARTIAL END WALL FRAMING
SCALE: NTS

TABLE 8-A.1: END WALL POST SPACING SCHEDULE

WIND SPEED (MPH)	EAVE HEIGHT		
	UP TO 7'	8' TO 9'	10' TO 12'
<input type="checkbox"/> 105	5'	5'	5'
<input type="checkbox"/> 115	5'	5'	4.5'
<input type="checkbox"/> 130	4.5'	4.5'	4'
<input type="checkbox"/> 140	4.5'	4.5'	3'
<input type="checkbox"/> 155	4'	4'	2.5'
<input type="checkbox"/> 165 - 180	3.5'	3'	2'

MANUFACTURED BY:



DRAWING INFORMATION

PROJECT: 12'-0" WIDE BUILDINGS
LOCATION: STATE OF MICHIGAN
PROJECT NO.: 451-22-1572
SHEET TITLE:

END WALL FRAMING

SHEET NO.: 8-A / 11
DRAWN BY: AW DATE: 5/17/22
CHECKED BY: OAA DATE: 5/17/22

LEGAL INFORMATION

- ANY DUPLICATION OF THIS DRAWING IN WHOLE OR PART IS STRICTLY FORBIDDEN. ANYONE DOING SO WILL BE PROSECUTED UNDER THE FULL EXTENT OF THE LAW.
- DRAWINGS VALID UP TO 1 YEAR FROM DATE OF ISSUE.

SEAL:

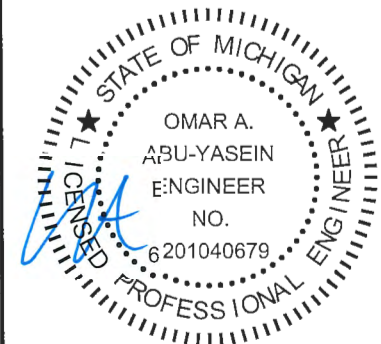

DATE EXPIRES: **03-24-2024**
DATE SIGNED: **05-20-2022**

MANUFACTURED BY:

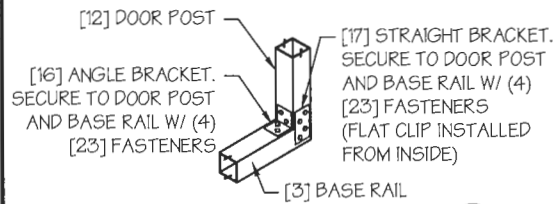

DOOR POST BASE RAIL CONN. DETAIL
SCALE: NTS

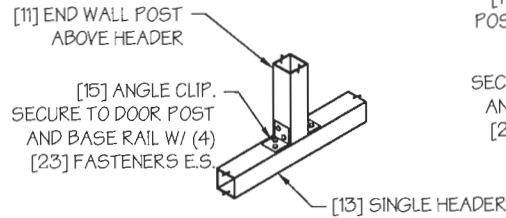

END WALL POST ABOVE HEADER CONN. DETAIL
SCALE: NTS

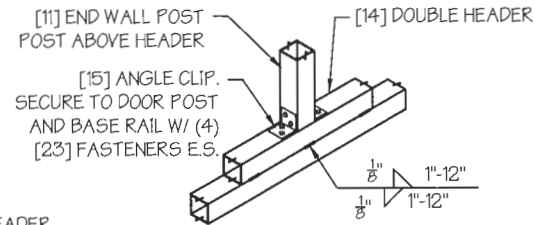

END WALL POST ABOVE DOUBLE HEADER CONN. DETAIL
SCALE: NTS

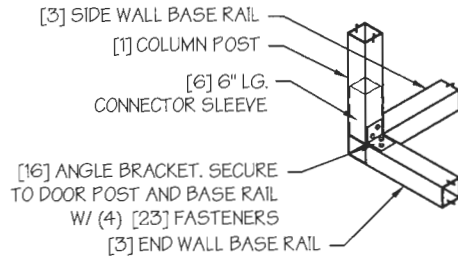

CORNER DETAIL
SCALE: NTS

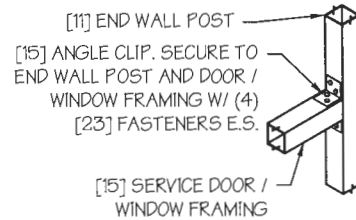

TYP. SERVICE DOOR / WINDOW FRAMING CONN. DETAIL
SCALE: NTS

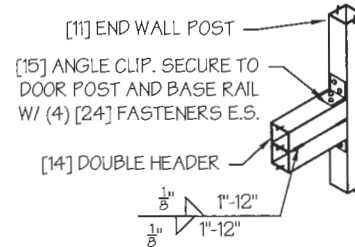

DOUBLE HEADER - END WALL POST CONN. DETAIL
SCALE: NTS

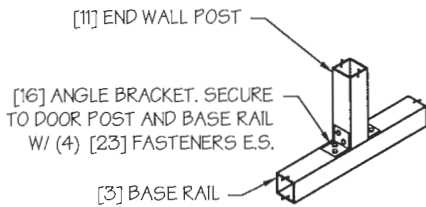

END WALL POST - BASE RAIL CONN. DETAIL
SCALE: NTS

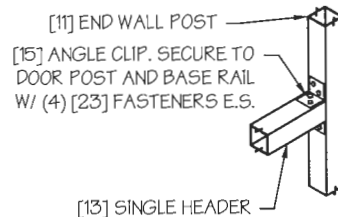

HEADER - END WALL POST CONN. DETAIL
SCALE: NTS

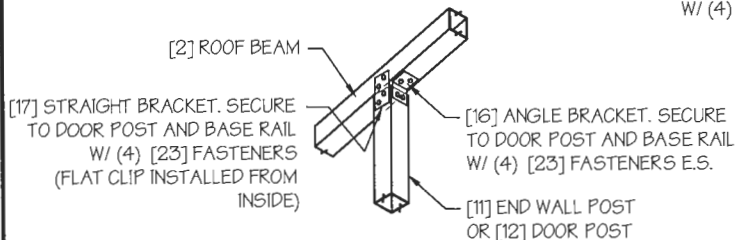

END WALL POST - ROOF BEAM CONN. DETAIL
SCALE: NTS

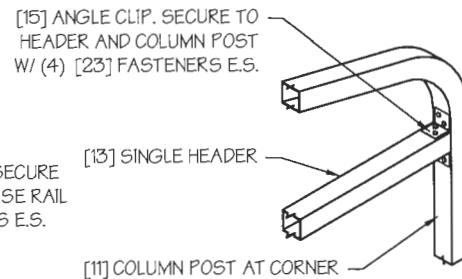

GABLE HEADER - CORNER POST CONN. DETAIL
SCALE: NTS

DRAWING INFORMATION

PROJECT: 12'-0" WIDE BUILDINGS

LOCATION: STATE OF MICHIGAN

PROJECT NO.: 451-22-1572

SHEET TITLE:

END WALL FRAMING DETAILS

SHEET NO.: B-B / 11

DRAWN BY: AW DATE: 5/17/22

CHECKED BY: OAA DATE: 5/17/22

LEGAL INFORMATION

- ANY DUPLICATION OF THIS DRAWING IN WHOLE OR PART IS STRICTLY FORBIDDEN. ANYONE DOING SO WILL BE PROSECUTED UNDER THE FULL EXTENT OF THE LAW.
- DRAWINGS VALID UP TO 1 YEAR FROM DATE OF ISSUE.

SEAL:

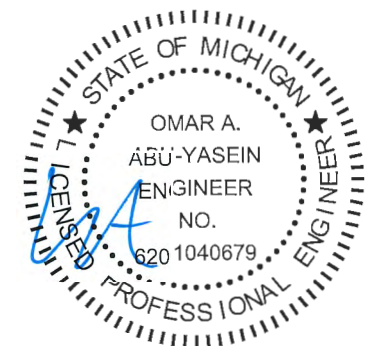

DATE EXPIRES: 03-24-2024

DATE SIGNED: 05-20-2022

MANUFACTURED BY:

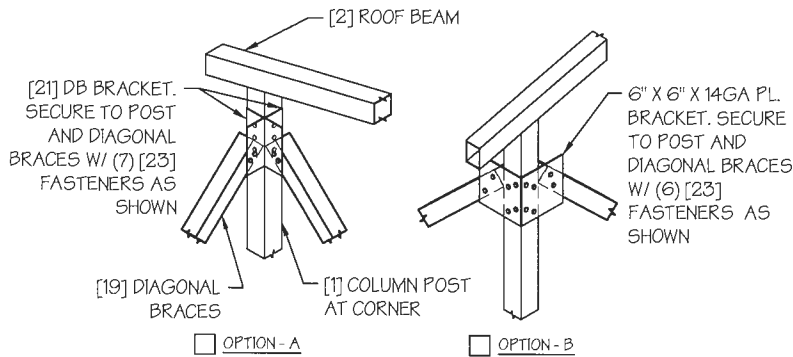

DIAGONAL BRACE TOP CORNER CONN. DETAIL* 1
SCALE: NTS

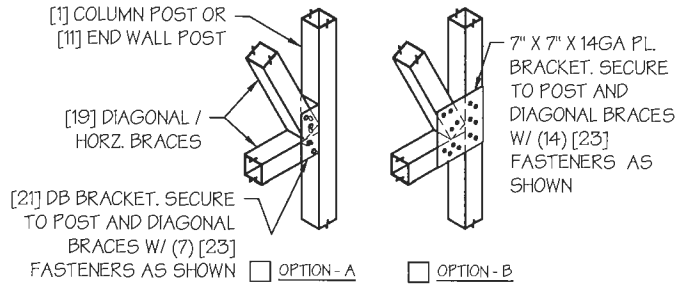

DIAGONAL BRACE - POST CONN. DETAIL* 2
SCALE: NTS

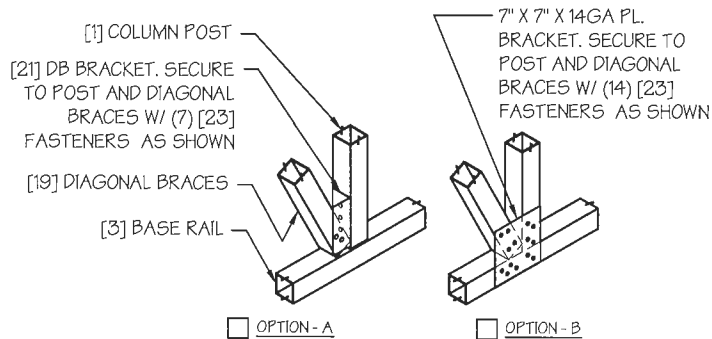

DIAGONAL BRACE BOT. CORNER CONN. DETAIL* 3
SCALE: NTS

* INSIDE VIEW SHOWN FOR CLARITY

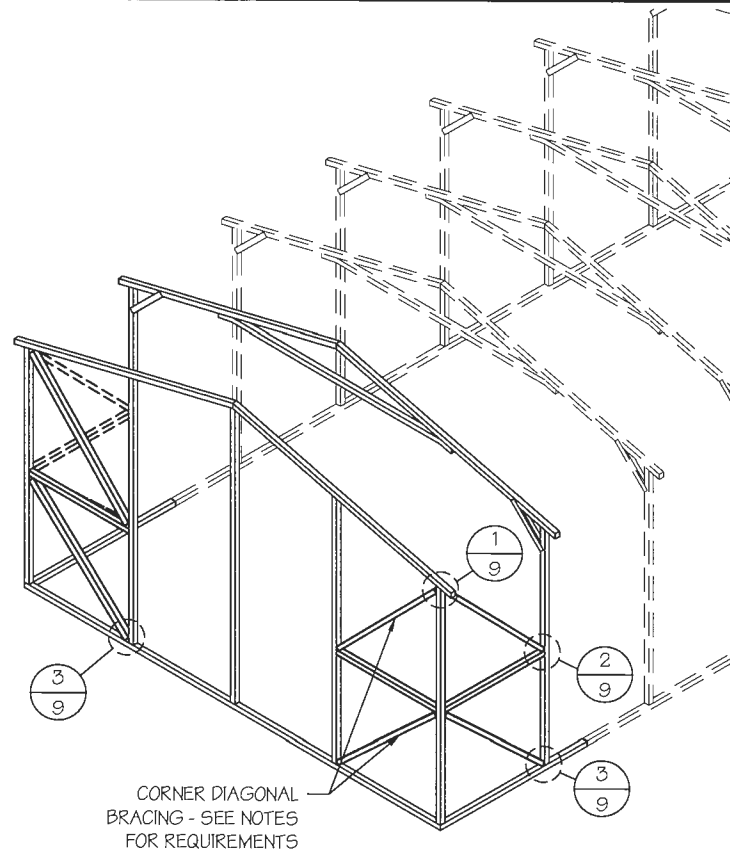

DIAGONAL BRACING AT CORNERS
SCALE: NTS

CORNER BRACING NOTES:

- DIAGONAL BRACING AT BUILDING CORNERS IS REQUIRED FOR ALL BUILDINGS IN LOCATIONS WHERE WIND SPEED IS 140 MPH OR GREATER.
 - FOR 3 SIDED ENCLOSED BUILDINGS 140 MPH OR GREATER WIND SPEED - THE BUILDING MUST BE DESIGNED WITH OPEN BUILDING SPACING AND DIAGONAL BRACING IS REQUIRED ON ALL ENCLOSED WALLS.
- SIDE-WALL DIAGONAL BRACING IS REQUIRED WHEN THE ADJACENT END-WALL IS PARTIALLY ENCLOSED.
- ALL BUILDINGS WITH IRREGULAR ENCLOSURE (SEE SHEET 5) WILL REQUIRE SIDE-WALL BRACING CLOSE TO THE PARTIALLY ENCLOSED END-WALL.

DRAWING INFORMATION

PROJECT: 12'-0" WIDE BUILDINGS

LOCATION: STATE OF MICHIGAN

PROJECT NO.: 451-22-1572

SHEET TITLE:

**CORNER BRACING
DETAILS**

SHEET NO.: 9 / 11

DRAWN BY: AW DATE: 5/17/22

CHECKED BY: OAA DATE: 5/17/22

LEGAL INFORMATION

- ANY DUPLICATION OF THIS DRAWING IN WHOLE OR PART IS STRICTLY FORBIDDEN. ANYONE DOING SO WILL BE PROSECUTED UNDER THE FULL EXTENT OF THE LAW.
- DRAWINGS VALID UP TO 1 YEAR FROM DATE OF ISSUE.

SEAL:

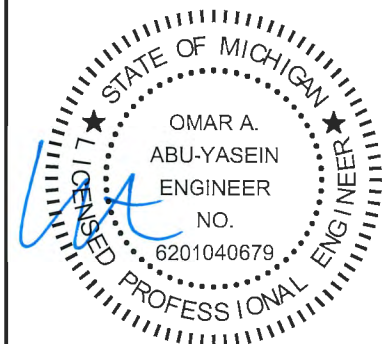

DATE EXPIRES: **03-24-2024**

DATE SIGNED: **05-20-2022**

MANUFACTURED BY:

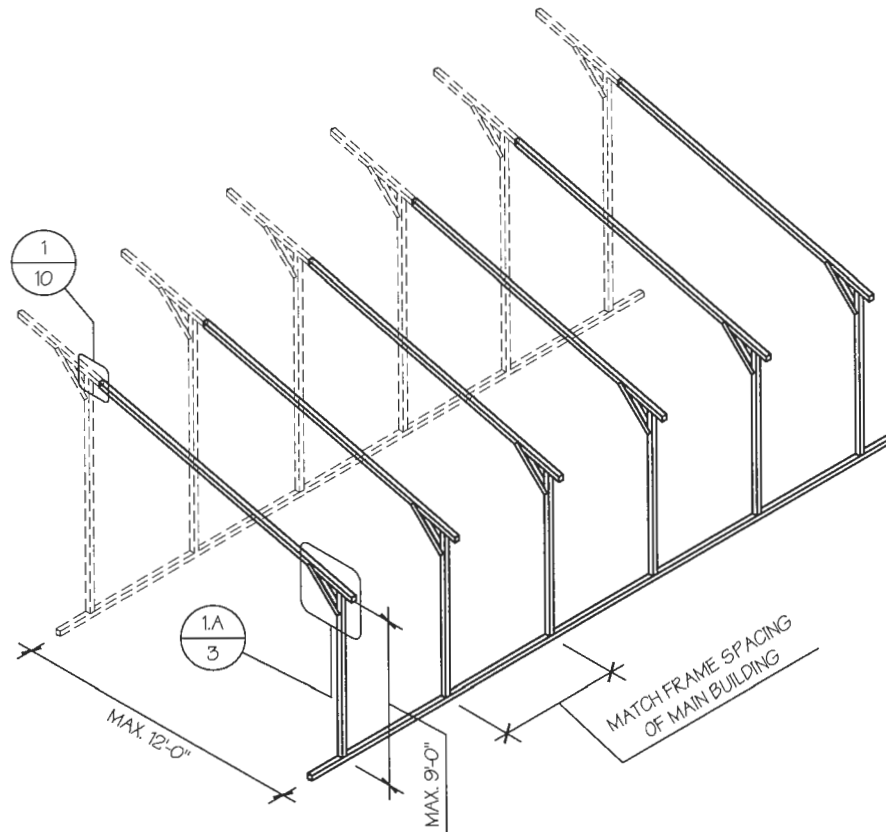

OPTIONAL LEAN-TO ADDITION
SCALE: NTS

DRAWING INFORMATION

PROJECT: 12'-0" WIDE BUILDINGS
LOCATION: STATE OF MICHIGAN
PROJECT NO.: 451-22-1572
SHEET TITLE:

OPTIONAL LEAN-TO ADDITION

SHEET NO.: 10 / 11
DRAWN BY: AW DATE: 5/17/22
CHECKED BY: OAA DATE: 5/17/22

LEGAL INFORMATION

- ANY DUPLICATION OF THIS DRAWING IN WHOLE OR PART IS STRICTLY FORBIDDEN. ANYONE DOING SO WILL BE PROSECUTED UNDER THE FULL EXTENT OF THE LAW.
- DRAWINGS VALID UP TO 1 YEAR FROM DATE OF ISSUE.

SEAL:

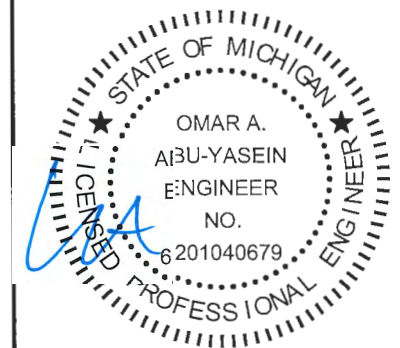

DATE EXPIRES: **03-24-2024**
DATE SIGNED: **05-20-2022**

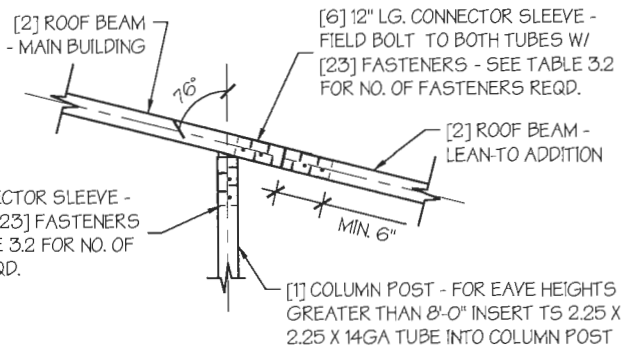

LEAN-TO ATTACHMENT DETAIL 1
SCALE: NTS

LEAN-TO ADDITION NOTES:

1. LEAN-TO ADDITIONS CAN BE ADDED ON EITHER OR BOTH SIDES OF THE BUILDING.
2. ROOF SLOPE, PURLIN, GIRT AND FRAME SPACING OF THE ADDITION HAVE TO MATCH THAT OF THE MAIN STRUCTURE.
3. IF THE LEAN-TO ADDITION IS "OPEN" (BOTH END WALLS OR SIDE WALL IS NOT ENCLOSED), THE DESIGN OF THE MAIN BUILDING HAS TO USE THE FRAME SPACING OF AN OPEN BUILDING FROM TABLE 4.

CONCRETE SLAB FOUNDATION NOTES:

- DESIGNS SHOWN ON THIS SHEET ARE FOR CONCRETE SLAB FOUNDATION. ANY OF THE FOUNDATIONS SHOWN ON SHEETS 11-A THRU C CAN BE USED.
- CONCRETE ANCHORS SHALL BE LOCATED NEXT TO EVERY POST AND ON EITHER SIDE OF OPENINGS. TWO ANCHORS SHALL BE INSTALLED AT CORNERS OF ENCLOSED BUILDINGS WITH END WALLS - ONE ON EACH BASE RAIL. IN LOCATIONS REQUIRING TWO ANCHORS DUE TO WIND, ONE ANCHOR IS TO BE ON EACH SIDE OF THE COLUMN POST.
- ANCHORS IN CLOSE PROXIMITY TO EACH OTHER MUST HAVE A MIN. 4" SPACING.
- MIN. NUMBER OF CONCRETE ANCHORS PER POST SHALL BE AS SHOWN IN TABLE 11-A.2.
- THE SIZE OF THE SLAB SHALL BE THE SIZE (WIDTH AND LENGTH) OF THE BUILDING PLUS $5\frac{1}{2}$ " FOR 14GA MATERIAL AND $5\frac{3}{4}$ " FOR 12GA MATERIAL.
- DEPTH OF SLAB TURN DOWN FOOTING SHALL BE GREATER THAN FROST DEPTH SPECIFIED PER LOCAL CODE.
- CONTROL JOINTS SHALL BE PLACED SO AS TO LIMIT MAX. SLAB SPANS TO 20' IN EACH DIRECTION.
- ASSUMED SOIL BEARING CAPACITY IS TO BE A MIN. OF 1500 PSF.
- CONCRETE STRENGTH TO BE A MIN OF 2500 PSI @ 28 DAYS.

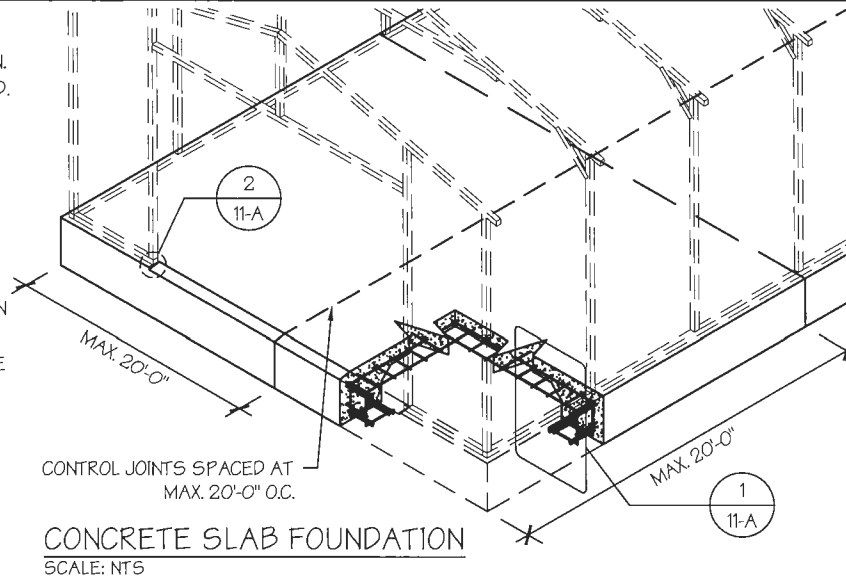

CONCRETE SLAB FOUNDATION
SCALE: NTS

MANUFACTURED BY:



DRAWING INFORMATION

PROJECT: 12'-0" WIDE BUILDINGS

LOCATION: STATE OF MICHIGAN

PROJECT NO.: 451-22-1572

SHEET TITLE:

FOUNDATION OPTION 1:
CONCRETE SLAB

SHEET NO.: 11-A / 11

DRAWN BY: AW DATE: 5/17/22

CHECKED BY: OAA DATE: 5/17/22

LEGAL INFORMATION

- ANY DUPLICATION OF THIS DRAWING IN WHOLE OR PART IS STRICTLY FORBIDDEN. ANYONE DOING SO WILL BE PROSECUTED UNDER THE FULL EXTENT OF THE LAW.
- DRAWINGS VALID UP TO 1 YEAR FROM DATE OF ISSUE.

SEAL:

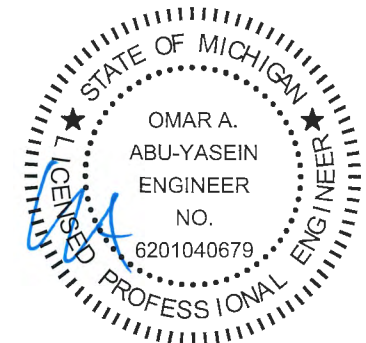

DATE EXPIRES: **03-24-2024**

DATE SIGNED: **05-20-2022**

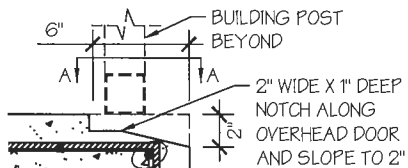

OVERHEAD DOOR NOTCH DETAIL
SCALE: NTS

TABLE 11-A.2: CONCRETE SLAB ANCHOR SCHEDULE

ENCLOSURE	WIND SPEED (MPH)	ANCHOR SIZE/NUMBER
ENCLOSED	105 TO 135	(1) 1/2"Ø X 7"
	136 TO 180	(2) 1/2"Ø X 7"
OPEN	105 TO 135	(1) 1/2"Ø X 7"
	136 TO 180	(2) 1/2"Ø X 7"

NOTES:

- ANCHORS ARE TO BE CONCRETE WEDGE OR EXPANSION ANCHORS.
- MIN. EMBEDMENT DEPTH TO BE $2\frac{1}{8}$ ".
- ANCHORS TO BE SPACED NO MORE THAN 6" FROM POSTS.

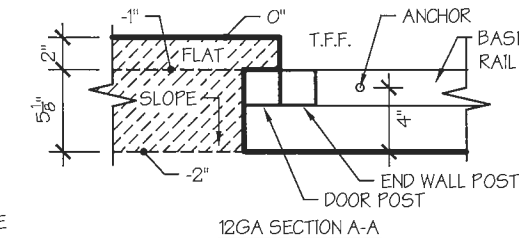
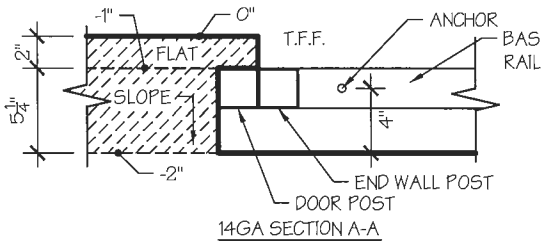
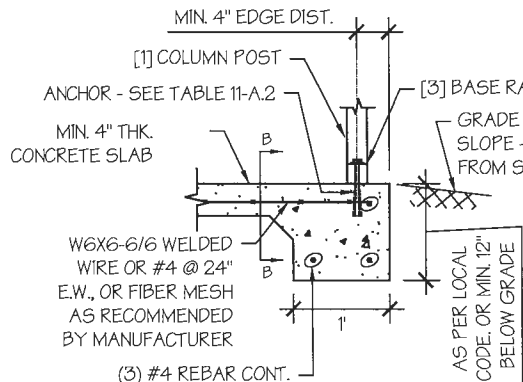

TABLE 11-A.1: NOTCH WIDTH

HORIZONTAL/OPEN		VERTICAL	
14GA	12GA	14GA	12GA
2 3/4"	2 7/8"	1 3/4"	1 7/8"

NOTE: DEPTH IS TO BE 1 1/2"



STANDARD EDGE DETAIL

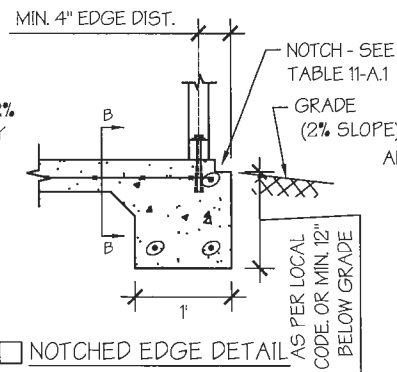

NOTCHED EDGE DETAIL

EDGE OFFSET DETAIL
SCALE: NTS

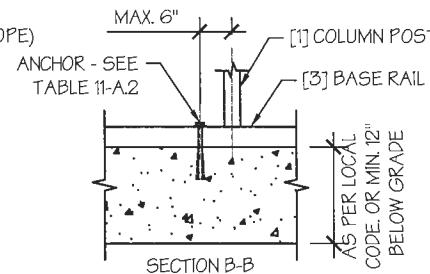

SECTION B-B

CONCRETE SLAB FOUNDATION NOTES:

- DESIGNS SHOWN ON THIS SHEET ARE FOR CONCRETE SLAB FOUNDATION. ANY OF THE FOUNDATIONS SHOWN ON SHEETS 11-A THRU C CAN BE USED.
- CONCRETE ANCHORS SHALL BE LOCATED NEXT TO EVERY POST AND ON EITHER SIDE OF OPENINGS. TWO ANCHORS SHALL BE INSTALLED AT CORNERS OF ENCLOSED BUILDINGS WITH END WALLS - ONE ON EACH BASE RAIL. IN LOCATIONS REQUIRING TWO ANCHORS DUE TO WIND, ONE ANCHOR IS TO BE ON EACH SIDE OF THE COLUMN POST.
- ANCHORS IN CLOSE PROXIMITY TO EACH OTHER MUST HAVE A MIN. 4" SPACING.
- MIN. NUMBER OF CONCRETE ANCHORS PER POST SHALL BE AS SHOWN IN TABLE 11-A.1.
- THE SIZE OF THE SLAB SHALL BE THE SIZE (WIDTH AND LENGTH) OF THE BUILDING PLUS 1/2" FOR 14GA MATERIAL AND 1" FOR 12GA MATERIAL.
- DEPTH OF SLAB TURN DOWN FOOTING SHALL BE GREATER THAN FROST DEPTH SPECIFIED PER LOCAL CODE.
- CONTROL JOINTS SHALL BE PLACED SO AS TO LIMIT MAX. SLAB SPANS TO 20' IN EACH DIRECTION.
- ASSUMED SOIL BEARING CAPACITY IS TO BE A MIN. OF 1500 PSF.
- CONCRETE STRENGTH TO BE A MIN. OF 2500 PSI @ 28 DAYS.

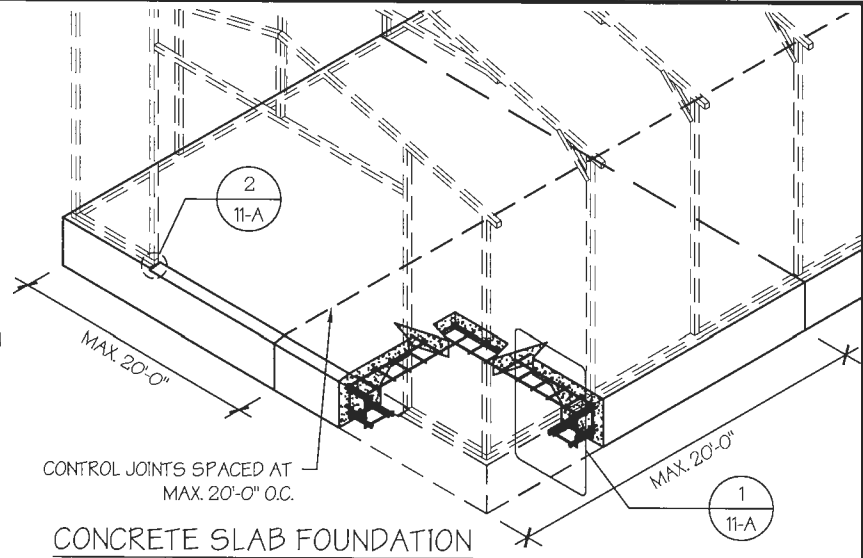

CONCRETE SLAB FOUNDATION

SCALE: NTS

TABLE 11-A.1: CONCRETE SLAB ANCHOR SCHEDULE

ENCLOSURE	WIND SPEED (MPH)	ANCHOR SIZE/NUMBER
ENCLOSED	105 TO 135	(1) 1/2"Ø X 7"
	136 TO 180	(2) 1/2"Ø X 7"
OPEN	105 TO 135	(1) 1/2"Ø X 7"
	136 TO 180	(2) 1/2"Ø X 7"

NOTES:

- ANCHORS ARE TO BE CONCRETE WEDGE OR EXPANSION ANCHORS.
- MIN. EMBEDMENT DEPTH TO BE 2 2/8".
- ANCHORS TO BE SPACED NO MORE THAN 6" FROM POSTS.

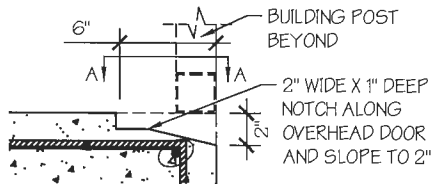

OVERHEAD DOOR NOTCH DETAIL

SCALE: NTS

2

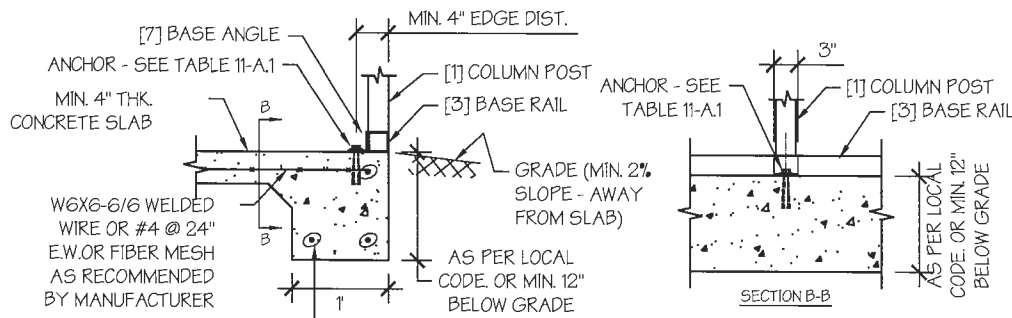
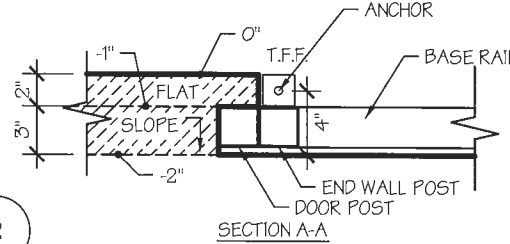

EDGE FLUSH DETAIL

SCALE: NTS

1

MANUFACTURED BY:



DRAWING INFORMATION

PROJECT: 12'-0" WIDE BUILDINGS

LOCATION: STATE OF MICHIGAN

PROJECT NO.: 451-22-1572

SHEET TITLE:

FOUNDATION OPTION 1:
FLUSH CONCRETE SLAB

SHEET NO.: 11-A / 11

DRAWN BY: AW DATE: 5/17/22

CHECKED BY: OAA DATE: 5/17/22

LEGAL INFORMATION

- ANY DUPLICATION OF THIS DRAWING IN WHOLE OR PART IS STRICTLY FORBIDDEN. ANYONE DOING SO WILL BE PROSECUTED UNDER THE FULL EXTENT OF THE LAW.
- DRAWINGS VALID UP TO 1 YEAR FROM DATE OF ISSUE.

SEAL:

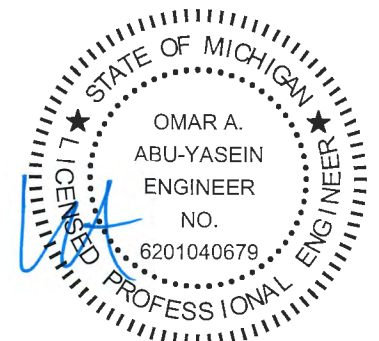

DATE EXPIRES: 03-24-2024

DATE SIGNED: 05-20-2022

TABLE 11-B.1: ANCHOR SCHEDULE

ENCLOSURE	WIND SPEED (MPH)	ANCHOR SIZE/NUMBER
ENCLOSED	□105 TO 135	(1) 1/2"Ø X 7"
	□136 TO 180	(2) 1/2"Ø X 7"
OPEN	□105 TO 135	(1) 1/2"Ø X 7"
	□136 TO 180	(2) 1/2"Ø X 7"

NOTES:

- ANCHORS ARE TO BE CONCRETE WEDGE OR EXPANSION ANCHORS.
- MIN. EMBEDMENT DEPTH TO BE 2 7/8".
- ANCHORS TO BE SPACED NO MORE THAN 6" FROM POSTS.

TABLE 11-B.2: CONC. STRIP SCHEDULE

WIND SPEED (MPH)	MIN. SIZE REQD.
□105 TO 130	12" X 12"
□140 TO 155	18" X 12"
□165 TO 180	26" X 12"
	21" X 15"
	18" X 18"

NOTES:

- WIDTH AND DEPTH DIMENSIONS CAN BE INTERCHANGED.

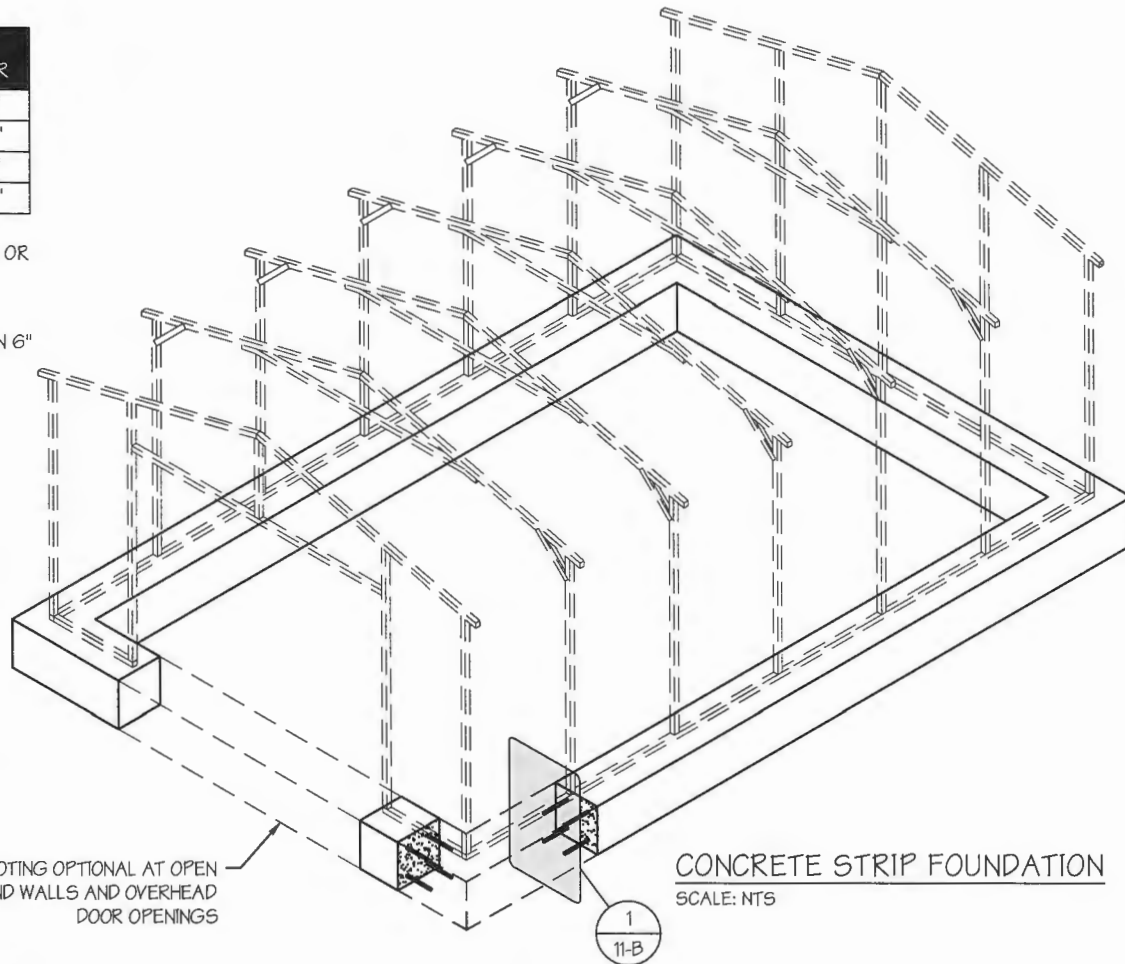

FOOTING OPTIONAL AT OPEN END WALLS AND OVERHEAD DOOR OPENINGS

CONCRETE STRIP FOUNDATION

SCALE: NTS

CONCRETE STRIP FOUNDATION NOTES:

- DESIGNS SHOWN ON THIS SHEET ARE FOR CONCRETE STRIP FOUNDATION. ANY OF THE FOUNDATIONS SHOWN ON SHEETS 11-A THRU C CAN BE USED.
- CONCRETE ANCHORS SHALL BE LOCATED NEXT TO EVERY POST AND ON EITHER SIDE OF OPENINGS. TWO ANCHORS SHALL BE INSTALLED AT CORNERS OF ENCLOSED BUILDINGS WITH END WALLS - ONE ON EACH BASE RAIL. IN LOCATIONS REQUIRING TWO ANCHORS DUE TO WIND, ONE ANCHOR IS TO BE ON EACH SIDE OF THE COLUMN POST.
- MIN. NUMBER OF CONCRETE ANCHORS PER POST SHALL BE AS SHOWN IN TABLE 11-B.1.
- ANCHORS IN CLOSE PROXIMITY TO EACH OTHER MUST HAVE A MIN. 4" SPACING.
- DEPTH OF CONCRETE STRIP FOOTING SHALL BE GREATER THAN FROST DEPTH SPECIFIED PER LOCAL CODE.
- ASSUMED SOIL BEARING CAPACITY IS TO BE A MIN. OF 1500 PSF.
- CONCRETE STRENGTH TO BE A MIN OF 2500 PSI @ 28 DAYS.
- BUILDING IS TO BE MOUNTED ON THE CENTER OF THE STRIP FOUNDATION.

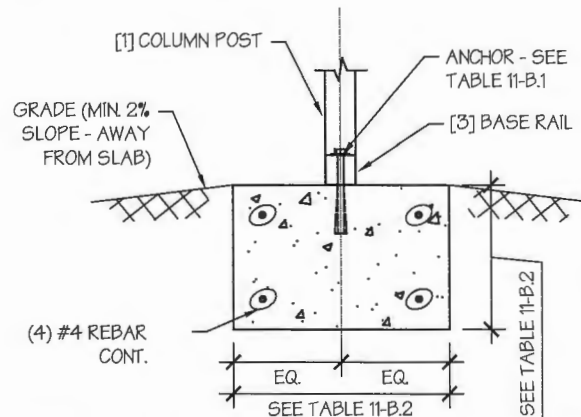

CONCRETE STRIP FOUNDATION DETAIL

SCALE: NTS

MANUFACTURED BY:



DRAWING INFORMATION

PROJECT: 12'-0" WIDE BUILDINGS

LOCATION: STATE OF MICHIGAN

PROJECT NO.: 451-22-1572

SHEET TITLE:

FOUNDATION OPTION 2:
CONCRETE STRIP

SHEET NO.: 11-B / 11

DRAWN BY: AW DATE: 5/17/22

CHECKED BY: OAA DATE: 5/17/22

LEGAL INFORMATION

- ANY DUPLICATION OF THIS DRAWING IN WHOLE OR PART IS STRICTLY FORBIDDEN. ANYONE DOING SO WILL BE PROSECUTED UNDER THE FULL EXTENT OF THE LAW. - DRAWINGS VALID UP TO 1 YEAR FROM DATE OF ISSUE.

SEAL:

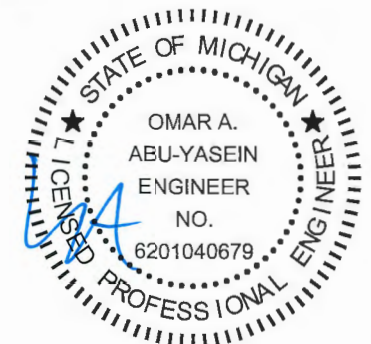

DATE EXPIRES: 03-24-2024

DATE SIGNED: 05-20-2022

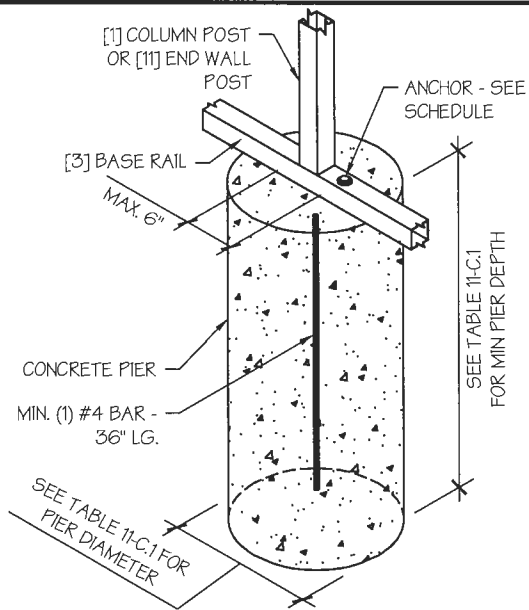

CONCRETE PIER DETAIL 1
SCALE: NTS

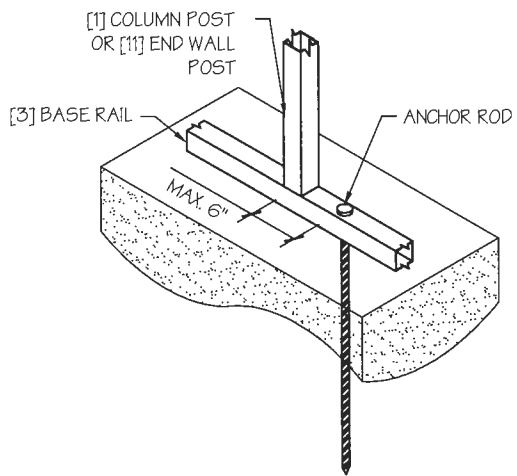

ANCHOR ROD INTO SOIL DETAIL 2
SCALE: NTS

TABLE 11-C.1: CONC. PIER SCHEDULE

WIND SPEED (MPH)	MIN. SIZE REQD.
□ 105 TO 130	18"Ø X 36"
□ 140 TO 155	18"Ø X 42"
□ 165 TO 180	18"Ø X 48"

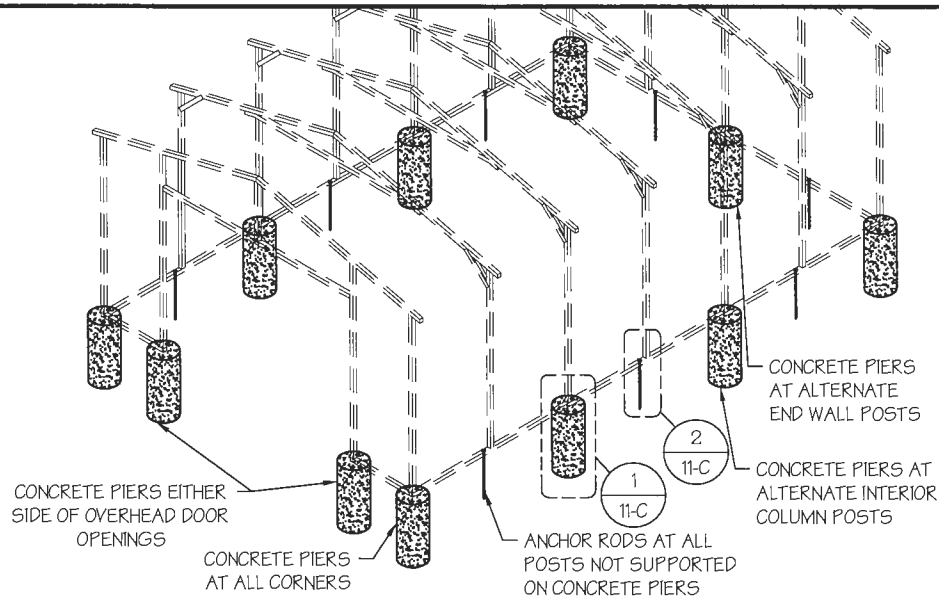

CONCRETE PIER FOUNDATION
SCALE: NTS

CONCRETE PIER FOUNDATION NOTES:

- DESIGNS SHOWN ON THIS SHEET ARE FOR CONCRETE PIER FOUNDATION. ANY OF THE FOUNDATIONS SHOWN ON SHEETS 11-A THRU C CAN BE USED.
- CONCRETE PIERS SHALL BE LOCATED AT ALL 4 CORNERS, ON EACH SIDE OF OVERHEAD DOOR OPENINGS AND ON ALTERNATE INTERIOR COLUMN POSTS AND END WALLS POSTS.
- TWO ANCHORS SHALL BE INSTALLED AT CORNERS OF ENCLOSED BUILDINGS WITH END WALLS - ONE ON EACH BASE RAIL. IN LOCATIONS REQUIRING TWO ANCHORS DUE TO WIND, ONE ANCHOR IS TO BE ON EACH SIDE OF THE COLUMN POST WITH A PIER.
- ANCHORS IN CLOSE PROXIMITY TO EACH OTHER MUST HAVE A MIN. 4" SPACING.
- MIN. NUMBER OF CONCRETE ANCHORS PER POST WITH A PIER SHALL BE AS SHOWN IN TABLE 11-C.2.
- TWO ANCHORS AND A PIER ARE REQUIRED AT DIAGONAL BRACING LOCATIONS WHEN REQUIRED.
- ALL POSTS NOT SUPPORTED ON CONCRETE PIERS SHALL BE ANCHORED TO THE GROUND WITH A 1/2" X 30" LG. THREADED ROD. RODS WILL HAVE A PRE-FORMED HEAD AT THE TOP AND ONE COAT OF RUST PROOF MATERIAL.
- PIERS SHALL BE FORMED BY DIGGING A HOLE OF THE SAME SIZE AS THE PIER ON LEVEL GRADE AND FILLING IT WITH CONCRETE. THRD. ROD ANCHORS SHOULD BE DROPPED INTO THE PIERS PRIOR TO POURING THE CONCRETE.
- ASSUMED SOIL BEARING CAPACITY IS TO BE A MIN. OF 1500 PSF.
- CONCRETE STRENGTH TO BE A MIN OF 2500 PSI @ 28 DAYS.

TABLE 11-C.2: ANCHOR SCHEDULE

ENCLOSURE	WIND SPEED (MPH)	ANCHOR SIZE/NUMBER
ENCLOSED	□ 105 TO 135	(1) 1/2"Ø X 7"
	□ 136 TO 180	(2) 1/2"Ø X 7"
OPEN	□ 105 TO 135	(1) 1/2"Ø X 7"
	□ 136 TO 180	(2) 1/2"Ø X 7"

NOTES:

- ANCHORS ARE TO BE CONCRETE WEDGE OR EXPANSION ANCHORS.
- MIN. EMBEDMENT DEPTH TO BE 2 3/8".
- ANCHORS TO BE SPACED NO MORE THAN 6" FROM POSTS.

MANUFACTURED BY:



DRAWING INFORMATION

PROJECT: 12'-0" WIDE BUILDINGS

LOCATION: STATE OF MICHIGAN

PROJECT NO.: 451-22-1572

SHEET TITLE:

FOUNDATION OPTION 3:
CONCRETE PIERS

SHEET NO.: 11-C / 11

DRAWN BY: AW DATE: 5/17/22

CHECKED BY: OAA DATE: 5/17/22

LEGAL INFORMATION

- ANY DUPLICATION OF THIS DRAWING IN WHOLE OR PART IS STRICTLY FORBIDDEN. ANYONE DOING SO WILL BE PROSECUTED UNDER THE FULL EXTENT OF THE LAW. - DRAWINGS VALID UP TO 1 YEAR FROM DATE OF ISSUE.

SEAL:

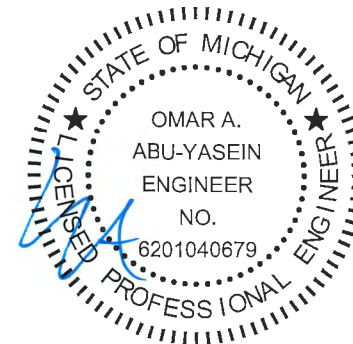

DATE EXPIRES: **03-24-2024**

DATE SIGNED: **05-20-2022**

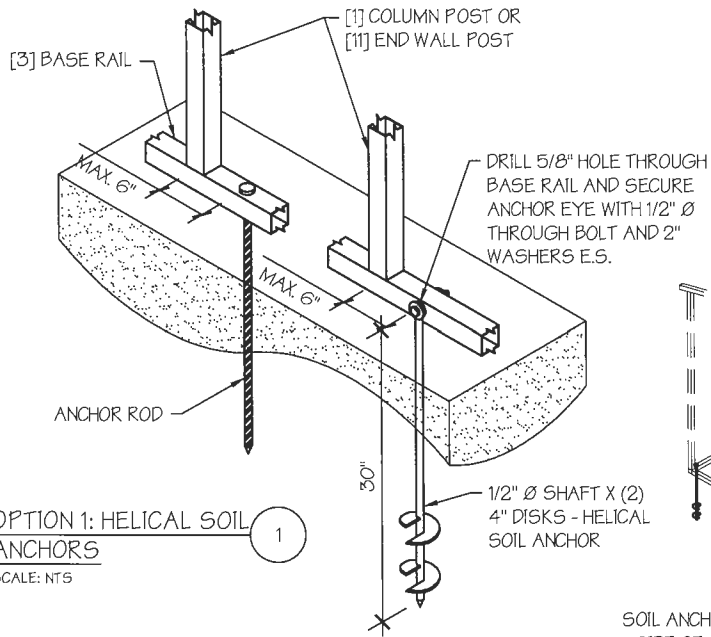

OPTION 1: HELICAL SOIL ANCHORS
SCALE: NTS

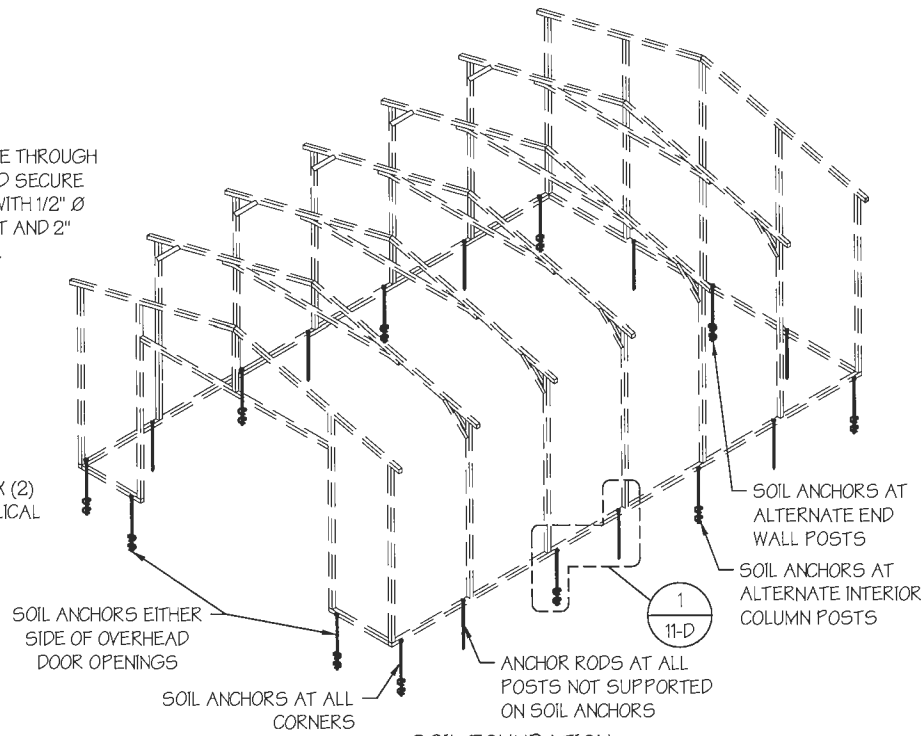

SOIL FOUNDATION
SCALE: NTS

SOIL FOUNDATION NOTES:

- DESIGNS SHOWN ON THIS SHEET ARE FOR SOIL ANCHOR FOUNDATION.
- SOIL ANCHORS (HELICAL OR ROCK/ASPHALT) SHALL BE LOCATED AT ALL 4 CORNERS, ON EACH SIDE OF OVERHEAD DOOR OPENINGS, ON POSTS WITH DIAGONAL BRACING IF REQUIRED, AND ON ALTERNATE INTERIOR COLUMN POSTS AND END WALLS POSTS.
- HELICAL ANCHORS ARE TO BE USED ONLY IF THE DRIVING TORQUE INTO THE GROUND IS 150 FT-LBS OR GREATER. MANUFACTURER IS NOT RESPONSIBLE FOR SOIL QUALITY AT SITE.
- HELICAL ANCHORS CAN ONLY BE USED FOR CLASS 2, 3 & 4 SOILS (SEE SOIL CLASSIFICATIONS THIS PAGE).
- ALL POSTS WITH NO ANCHORS ADJACENT SHALL BE ANCHORED TO THE GROUND WITH A 1/2" X 30" LG. ROD. RODS WILL HAVE A PRE-FORMED HEAD AT THE TOP AND ONE COAT OF RUST PROOF MATERIAL.
- ASSUMED SOIL BEARING CAPACITY IS TO BE A MIN. OF 1500 PSF.

SOIL CLASSIFICATIONS:

SOIL CLASS	DESCRIPTION
2	SANDY GRAVEL AND GRAVEL, VERY THIN DENSE AND/OR CEMENTED SANDS, COARSE GRAVEL/COBBLES, PRELOADED SILTS, CLAYS AND CORAL.
3	SAND, SILTY SAND, CLAYEY SAND, SILTY GRAVEL, MEDIUM DENSE COARSE SANDS, SANDY GRAVEL, VERY STIFF SILT AND SANDY CLAYS.
4	LOOSE TO MEDIUM DENSE SANDS, FIRM TO STIFF CLAYS AND SILTS AND ALLUVIAL FILLS.

*FROM HUD "MODEL MANUFACTURED HOME INSTALLATION STANDARDS"

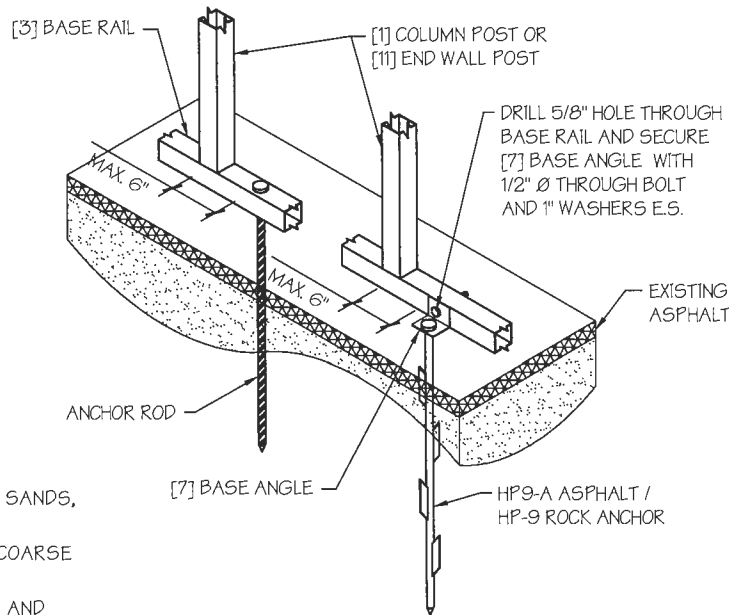

OPTION 2: ROCK / ASPHALT ANCHORS
SCALE: NTS

MANUFACTURED BY:



DRAWING INFORMATION

PROJECT: 12'-0" WIDE BUILDINGS

LOCATION: STATE OF MICHIGAN

PROJECT NO.: 451-22-1572

SHEET TITLE:

FOUNDATION OPTION 4:
SOIL ANCHORS

SHEET NO.: 11-D / 11

DRAWN BY: AW DATE: 5/17/22

CHECKED BY: OAA DATE: 5/17/22

LEGAL INFORMATION

- ANY DUPLICATION OF THIS DRAWING IN WHOLE OR PART IS STRICTLY FORBIDDEN. ANYONE DOING SO WILL BE PROSECUTED UNDER THE FULL EXTENT OF THE LAW. - DRAWINGS VALID UP TO 1 YEAR FROM DATE OF ISSUE.

SEAL:

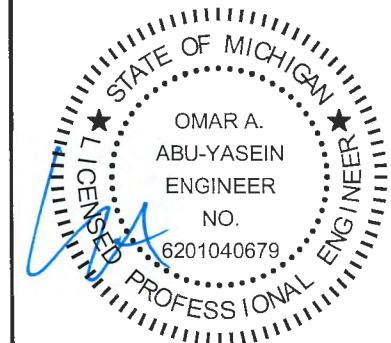

DATE EXPIRES: **03-24-2024**

DATE SIGNED: **05-20-2022**